

## MINI 2 CHANNELS MIXER AMPLIFIER LTS.A220 Operation manual



*Please follow the instructions in this manual to obtain the optimum results from this unit.  
We also recommend that you keep this manual handy for future reference.*

## TABLE OF CONTENTS

1. Introduction.....	Page 3
2. Bridge or stereo operation.....	Page 3
3. Features.....	Page 3
4. Front panel layout.....	Page 4
5. Rear panel layout.....	Page 4
6. Schematic.....	Page 4
7. Connection / operation.....	Page 5
8. Limiter.....	Page 5
9. Specifications.....	Page 5
10. Precaution for use.....	Page 6
11. Simple check and handling.....	Page 6

## WARNING

The minimum speaker impedance for stereo (2 channel operation) is 4 ohm each. The minimum speaker impedance for mono/bridge is 8 ohm.

If you connect and use the unit with lower speaker Impedance than what is listed above you will damage the unit and possibly other equipment that is connected to the machine.

Do not ground the speaker output terminals. The speaker terminals may not be at ground potential.

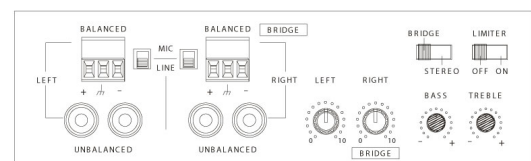

## 1. INTRODUCTION

Thank you for purchasing the mini mixer amplifier. This unit is designed for powering speakers in small environments. Inspection / warranty : Unpack and inspect the amplifier and its packaging. If obvious physical damage is noticed, contact the carrier immediately to make a damages claim. We suggest saving the shipping carton and packing material for safe transport of the unit.

## 2. BRIDGE OR STEREO OPERATION

To activate mono-bridge operation, press the configuration switch slide switch in the direction as required.

## 3. FEATURES

- Class D high efficiency amplifier
- 2 MIC / line switchable inputs : 2 unbalanced dual RCA auxiliary inputs and 2 balanced MIC / line switchable inputs by phoenix connectors
- Input 1 and input 2 volume controls, bass and treble tone controls
- 2 channel outputs by phoenix connector, bridge or stereo output two options, with bridge / stereo switch
- Built-in limiter for low noise and efficient operation, with limiter on / off switch
- DC 24 V power supply adapter is included
- Smart compact size for tabletop or wall mount design

**Note :** This manual assumes the user has a working knowledge of :

- Audio electronics
- Balanced and unbalanced connections
- Proper signal level setting

## 4. FRONT PANEL LAYOUT

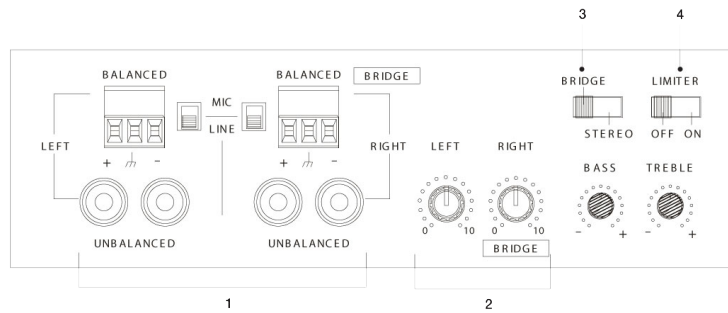

1. Inputs : RCA line level and balance barrier screw terminals.
2. Channel volume control : Adjusts signal level from line input to line / power and speaker outputs.
3. Bridge / mono switch : Selects operation of stereo or mono bridge input and output operation.
4. Limiter switch : Switches limiter circuit on or off.

## 5. REAR PANEL LAYOUT

1. 24V DV : For connection to power supply.
2. Speaker output : Barrier screw terminals

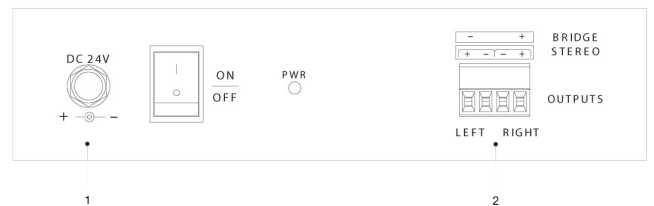

## 6. SCHEMATIC

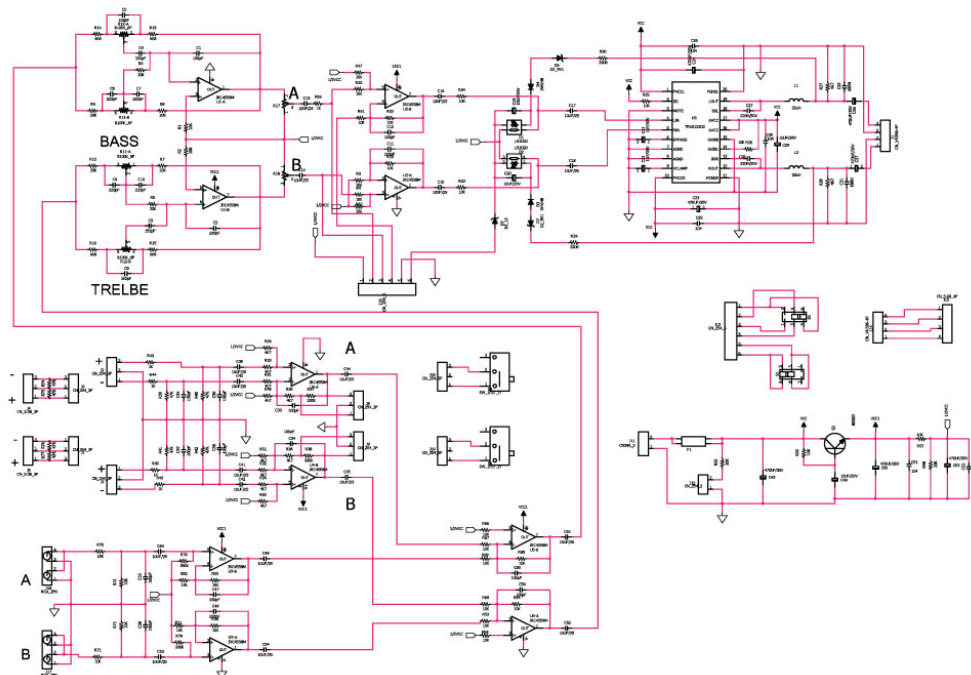

## 7. CONNECTION / OPERATION

- Connect input sources such as CD player, DVD player or projector outputs to the unit's inputs.
- Select bridge or stereo function.
- The unit shipped in stereo mode. To select bridge mode, slide in the switch until it locks into position.
- Connect the outputs from the unit to your speakers. The stereo and bridge outputs are labelled on the speaker outputs of the unit.
- We recommend selecting the limiter on function but the circuit may be disabled by selecting the off position.



The holes in the sides of the unit are for the attachment of a zip tie (not included) for power cord strain relief as required

## 8. LIMITER

The limiter is a function that prevents very loud signals from passing through it by limiting the signal volume temporarily to a normal level. This prevents damage to the speakers or the unit itself.

The limiter utilises a circuit that decrease the amount of very signals. It does not cut out all potentially loud signal. Proper installation and The limiters primary function is to help prevent one time very loud signals such as a dropping of a microphone or short loud parts of program material.

Set up is crucial . If you are experiencing distortion, turning the limiter on may help but it is not intended for total dynamics control.

## 9. SPECIFICATIONS

Line input	775 mV /10K ohm
Speaker outputs	4 - 8 ohm
MIC input	5 mV / 600 ohm
Frequency response	50 Hz - 18 KHz (+2 dB)
Supply voltage	24 VDC
T.H.D	Less than 0.1% at 1 KHz / 1/3 rated power
S/N ratio	Better than 85 dB
Efficiency	85%
Dimension (mm)	230 x 115 x 56
Weight	0.9 kg

## 10. PRECAUTIONS FOR USE

1. When amplifier is working , volume control (controlled on mixer) is from small to big, until moderate. When close it, volume control (controlled on mixer) is from big to small, then close it.
2. During amplifier working process, it cannot be changed the work pattern of amplifiers or the overload of speakers by random or else, it will damage the amplifier easily. Usually, it should confirm the work pattern.
3. During amplifier working process, it cannot be changed the plugs of every audio devices in acoustic amplification system by random, including the plug of mixer. Or else, it will easily cause pulse signal, then from HPPMW by amplifier, until lead to LNB of audio, make the LNB burned and amplifier overload then destroy the amplifier.
4. Prohibit overload during amplifier connection as per rated power.

## 11. SIMPLE CHECK AND HANDLING

1. No power : Check whether the adapter is good or not, whether the power plug or power wire is good or not. If not, please change the power wire. Then check whether the indicator of adapter is on or not, whether there is 24V DC power output, if no, please change a new adapter.
2. No sound after connecting amplifier with speaker : Check whether the speaker is overload and simultaneously check whether the speak is short circuit. Check whether there is output in amplifier after the speaker is regular.
3. Too big noise : Check whether the connection of the devices is good, whether it is with shield, whether it is overload or whether the audio signal is too big.

# LINEARSOUND



---

Linear Technologie • 11 rue du Puits Rochefort • 42 100 Saint-Etienne  
Tél: +33 (0)4 77 81 49 49 • Fax: +33 (0)4 77 81 49 40 • [www.lineartech.fr](http://www.lineartech.fr)