

LINEARCOM3000

INFRARED RADIATOR LC3.IRR25

Operation manual





TABLE OF CONTENTS

1. Safety operation.....	Page 3
2. System introduction.....	Page 4
3. Digital infrared radiator.....	Page 9

1. SAFETY OPERATION

Firstly, thank you very much for using LINEARCOM3000 conference system. To make sure safety of equipment and user, please read this safety instruction carefully before installing and using and operate seriously according to this manual. Also please keep this safety instruction for future reference. Notices are as below :

1. Wiring during installation must follow national electric safety standards, national fireproofing regulations and all related local regulations.
2. Protect the power cord from being walked on and do not stack things on the power cord, particularly at plugs.
3. To make sure earth wire connecting well. Do not use 2 - pin plugs. Power supply : 220V 50 Hz.
4. Power supply cords :
 - America, Japan : AC 110V ~ 120V 60 Hz
 - Asia, Europe : AC 220V ~ 240V 50 Hz
5. The packaging of equipment is designed for protecting 1.5 meters dropping but please prevent from stress and shocking during transportation, installation and storing.
6. Do not place the system equipments on too cold or too hot room.
7. Keep good ventilation to protect the machine.
8. Unplug the system during wet weather or when unused for long periods of time.
9. Must unplug the equipment before below operations :
 - Taking down or resetting any part on machine
 - Reconnecting any plug in system
10. Do not disassemble or maintain the product by non-authorized personnel to avoid accident or damage. Warning label is as below :

CAUTION RISK OF ELECTRIC SHOCK DO NOT OPEN		This symbol is intended to alert the user of the presence of insulated dangerous voltage within the product's enclosure that may present a risk of electric shock
		This symbol is intended to alert the user of important operating and maintenance (servicing) instructions in the literature provided with the equipment

11. Prevent from any chemicals or liquid.
12. Please check all the connections completely before turning on. Check the set-up of main unit before usage.
13. If you find top warning label on product, it means : Do not open the machine cover to avoid electric shock. Also please do not place the useless part in the case. Any trouble, please contact with the authorized personnel.

2. SYSTEM INTRODUCTION

Brief introduction

LINEARCOM3000 is a series product of digital infrared language distribution system. It uses both digital infrared audio transmitting and control technique and an IR digital infrared chip. They own LINEARCOM3000's intellectual property. IRRC08 can be used in simultaneous interpretation systems for multi-language conferences.

In simultaneous interpretation systems, the interpreter translates the speaker's speech, the translated audio transmits through the conference venue by modulated infrared radiation and the delegates listen to wanted language by infrared receiver via earphone.

The system can also be used for other audio signal distribution occasions, such as urgent mode, free mode audio signal output.

This system is compliant to IEC 61603-7 (international standard of digital infrared transmission) and IEC60914 (conference systems-electrical and audio requirements, same as domestic standard GB/T 15381-94), moreover, it is compatible with other IR systems, compliant to IEC 61603-7. Parts of IEC 61603 are used in this manual for a better understanding of both theory and technique of the system.

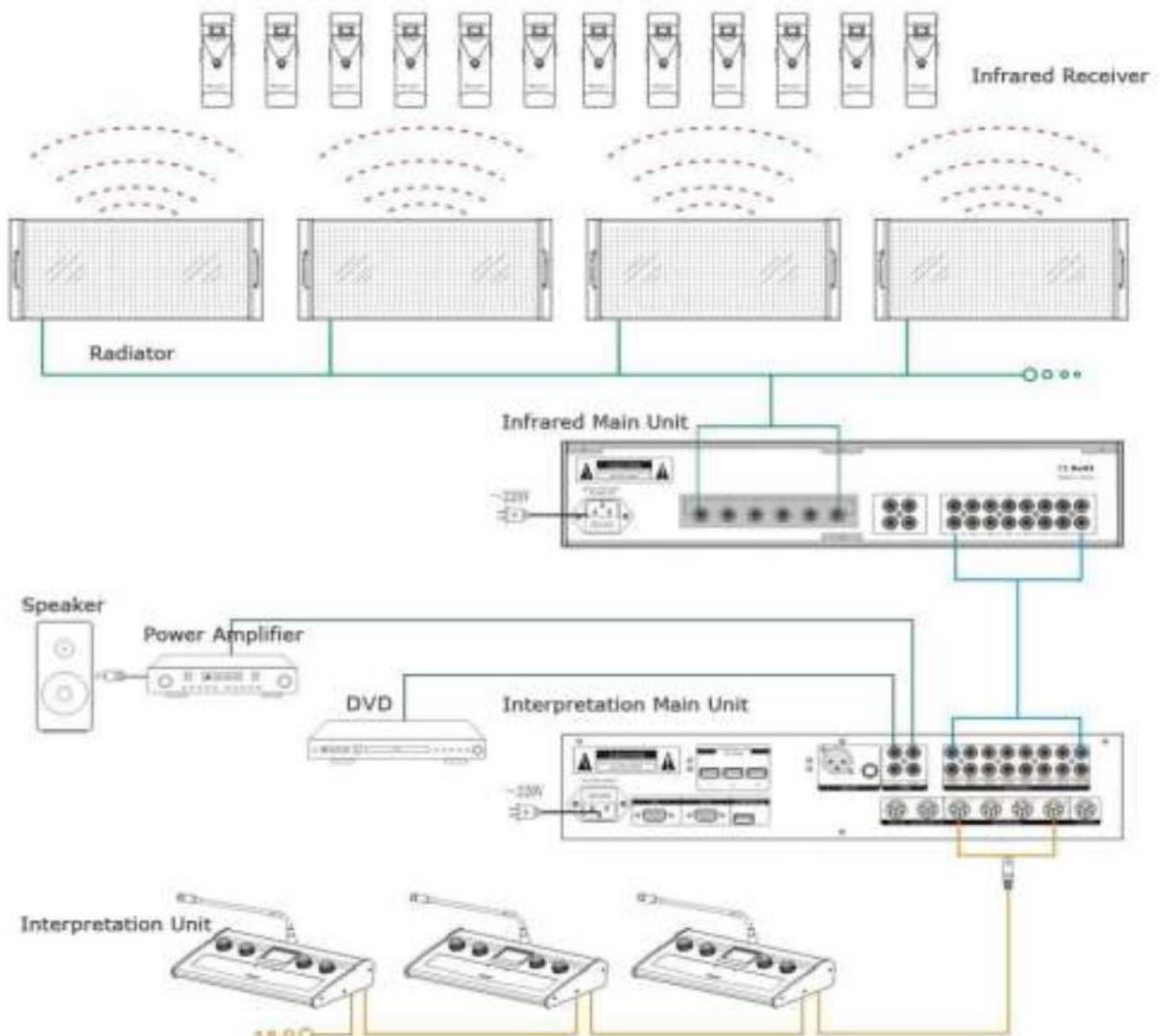

System composition

The system consists of a number (N) of audio sources, either analogue or digital, which are connected to a transmitter. The transmitter processes the audio signals into an electrical output to feed the infrared radiator. The infrared signal is received by the infrared receiver that processes the signal and outputs an audio signal and/or associated data.

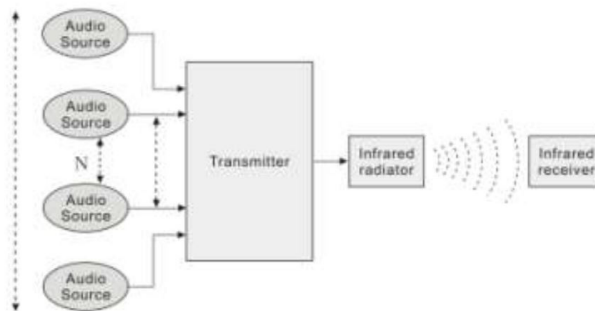

System radiation signal

IRR25 uses high frequency carrier signals (typically 2~8 MHz) to prevent interference by modern light sources. Fully digital audio processing guarantees a constant high audio quality. The signal processing in the main unit consists of the following main steps :

1. Code : Each analogue audio channel is converted to a digital signal; the digital signals are compressed to increase the amount of information that can be distributed on each carrier (compression ratio is related to required audio quality); groups of up to 4 digital signals are combined into a digital information steam. Extra fault algorithm information is added. This information is used by the receivers for fault detection and correction.
2. Modulation : A high frequency carrier signal is phase-modulated with the digital information stream by digital wireless base station digital modulation technique.
3. Filter
4. Magnify
5. Radiation : Up to 8 modulated carrier signals are combined and sent to the IR radiators, which convert the carrier signals to modulated infrared light.

In the IR receivers, a reverse processing is used to convert the modulated infrared light to separate digital audio channels.

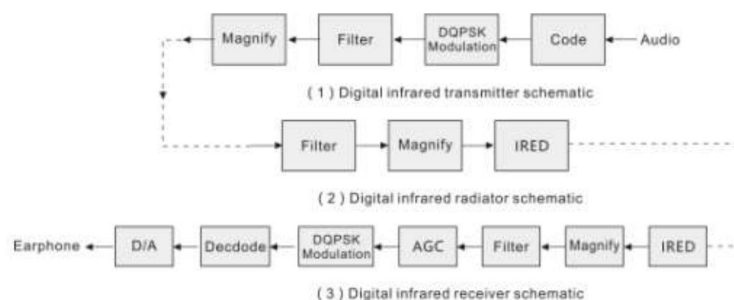

Carriers

System is transmitting within the 2 ~ 8 MHz frequency band. It can transmit up to 8 different carrier signals (depending on the transmitter type) Carriers 0 to 5 are according to IEC 61603-7.

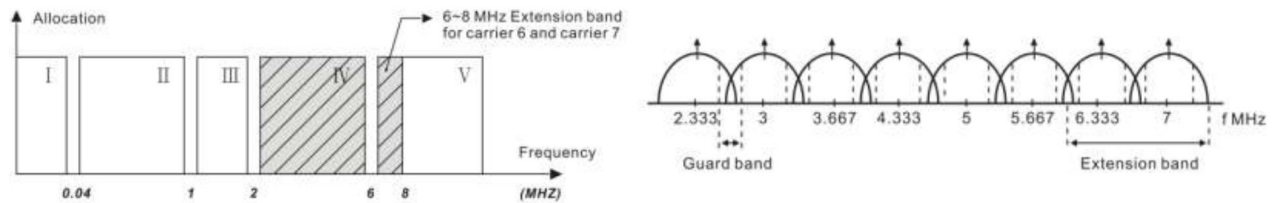

Aspects of infrared distribution

A good digital infrared language distribution system ensures that all delegates in a conference venue receive the distributed signals without disturbance. This is achieved by using enough and well positioned radiators, so that uniform IR signal with adequate strength can be received at any place of the conference venue.

When planning an infrared distribution system several aspects influencing the uniformity and quality of the infrared signal should be considered. These are discussed in the next sections.

Ambient lighting

IRRC08 can be operated without any problem even if fluorescent lamps (with or without electronic ballast or dimming facility) such as TL lamps or energy saving lamps are switched on.

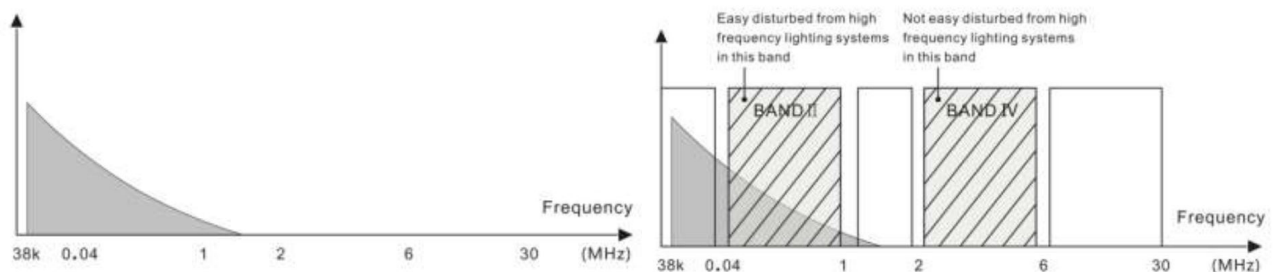

For venues with large, unshielded windows, more radiators should be added. For outdoor use, a site test will be required to determine the required amount of radiators. With sufficient radiators, the receivers will work well, even in bright sunlight.

Objects, surfaces and reflections

Just like visible light, infrared radiation is reflected from hard surfaces and refracted by hyaloid (glassy or transparent appearance) objects. Both objects in the conference venue and structure of the walls and ceilings will influence the distribution of infrared light.

Infrared radiation is reflected from almost all hard surfaces. Smooth, bright or shiny surfaces reflect well. Dark or rough surfaces absorb a large part of the infrared energy. Normally surfaces opaque to visible light are also opaque to infrared radiation. Shadows from walls and furniture will influence the transmission of infrared light. This can be solved by using a sufficient quantity of radiators. They should be positioned in a manner to provide an infrared field strong enough to cover the whole conference area. Take care not to direct radiators towards uncovered windows, or most of this radiation will be lost.

The direction and sensitivity of receiver unit

The sensitivity of a receiver is at its best when it is aimed directly towards a radiator. To minimize the disadvantage of this aspect, IRRC08 receiver adopts an ingenious structural design with peculiar 270° ultra wide angle to get perfect IR capture and sound quality at any disposition.

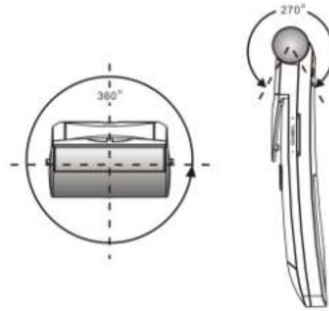

The coverage area of radiator

The number of transmitted carriers and the output power of the radiator determine the coverage area of a radiator. The total radiation energy of a radiator is distributed over transmitted carriers. The coverage area becomes proportionally smaller if more carriers are used. The receiver requires a strength of the IR signal of 4 mW / m² per carrier to work well (resulting in an 80 dB S/N ratio for uninterrupted audio channels)

The cross section of the 3 dimensional radiation with the reception level of participants is the footprint (the dark grey area in figure 2.9 to figure 2.10) In this area, the direct signal is strong enough to ensure proper reception when the receiver is directed towards the radiator. The size and position of the footprint depends on the mounting height and the angle of the radiator.

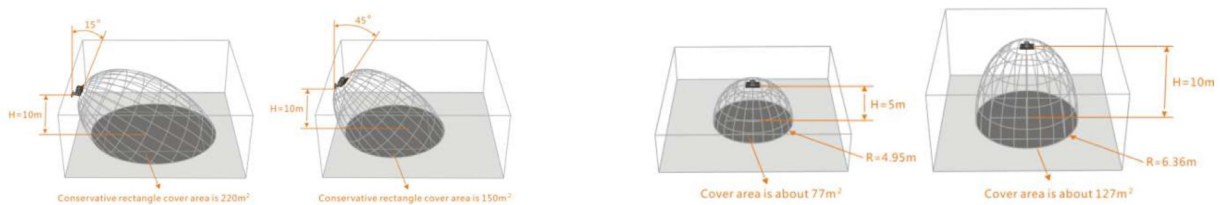

Area contrast of different installation height

Area contrast between 15° and 45° to the ceiling

Positioning the radiators

Because infrared radiation can reach a receiver directly and / or via diffused reflections, it's important to take this into consideration when installing the radiators. For best reception quality, receivers should pick up direct infrared radiation. In addition reflections will improve the signal reception. In big conference halls, infrared signal will be blocked by the people in front of the receiver. For that reason the radiator should be installed at an appropriate height, usually not below 2.5 meters.

For concentrically arranged conference venues, radiators located high up and faced to the center from every angle can cover the area very efficiently. If the direction of the receiver changes, e.g. changing seat direction, the radiators can be installed in the corners of the room.

In the case the seating is always directed towards the IR emitting source, there are no radiators needed at the back.

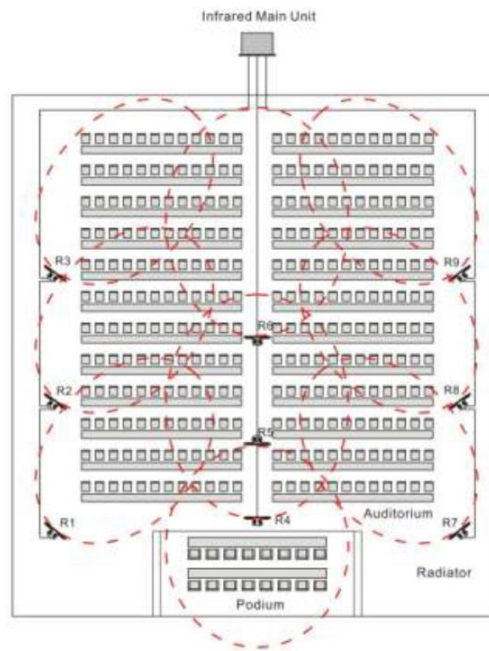

If the path of the infrared signals is blocked, e.g. under balconies, at least one additional radiator is needed to cover the 'shaded' area.



Overlapped footprints and multi-path effect

If footprints of two radiators overlap, the total coverage area maybe larger than the sum of the two separate footprints. In an area with overlap effect, the individual radiation signals of two radiators are added, resulting in an increase of the radiation intensity, larger than the required intensity.

However, due to the differences in the delays of the signals from two or more radiators, the signals may cancel out each other (multi-path effect). In a worst-case situation, loss of reception at some positions (black spots) may be the consequence.

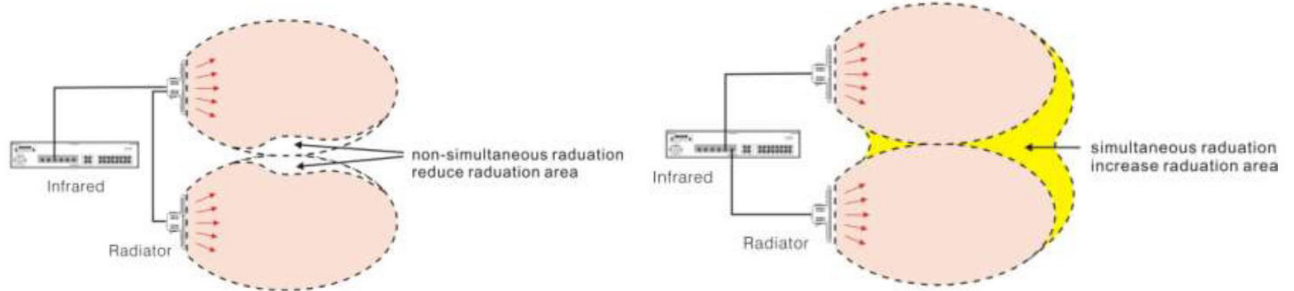

Increased coverage area caused by added radiation power

Reduced coverage area caused by differences in cable signal delay

The lower the carrier frequency, the less susceptible the receiver is for differences in signal delays.

The signal delays can be compensated by adjusting the delay compensation switches on the radiators.

3. DIGITAL INFRARED RADIATOR

Infrared radiator accepts carrier signals generated by the main unit and emits infrared radiation, carrying up to 32 audio distribution channels. Radiators are connected to the HF (BNC) connectors of the IR main unit. A maximum of 30 radiators, hand by hand connected, can be connected to each of these outputs. If the radiator does not receive a carrier, it switches to stand-by state automatically. If the radiator is overheating, it will automatically switch from full power to half power, or from half power to stand-by state.



- Compliant to IEC61603-7 and IEC 60914 international standard.
- Compatible with the infrared simultaneous interpretation system which is compliant to IEC61603-7.
- Various installation modes : A-frame stand, gimbals or other installation modes.
- Manual full power and half power switch which is convenience to apply in large/medium/small conference halls.
- Universal power supply, suitable for worldwide. LED displays signal and working situation real time.
- Cable transmission delay compensation function, range of delay compensation adjustment is from "00" to "99".
- 15W / 25W / 35W transmitting power, transmitting distance can reach 50M, radiate angle: Horizontal $\pm 40^\circ$, vertical $\pm 22^\circ$.

LINEARCOM3000

- HF input / output socket (2 x BNC), is used to connect infrared controller / and series connect next infrared radiator.
- Dimension : 500 x 214 x 178 mm.
- Color : Silver, golden, black.
- Weight : 5.2 kg.

Technical parameter of infrared radiator

Modulation mode	Digital wireless base station
Carrier frequency	2-8 MHz
Audio processing	IR-DSP
Infrared radiate power	25W
Working voltage	AC110 / 220V
Working temperature	0 - 40°C
Radiate distance	50M
Half angle radiate angle	Horizontal $\pm 40^\circ$ / vertical $\pm 22^\circ$
Max. current consumption	1700 mA
Min. current consumption	80 mA
Input impedance	75 Ohm
Carrier wavelength	850 nm
Cooling	Convective cooling
LED display	Power / signal
Dimension	500 x 214 x 178 mm
Weight	5.2 kg (excludes power supply cable)
Color	Silver, golden, black

Infrared radiator panel schematic diagram

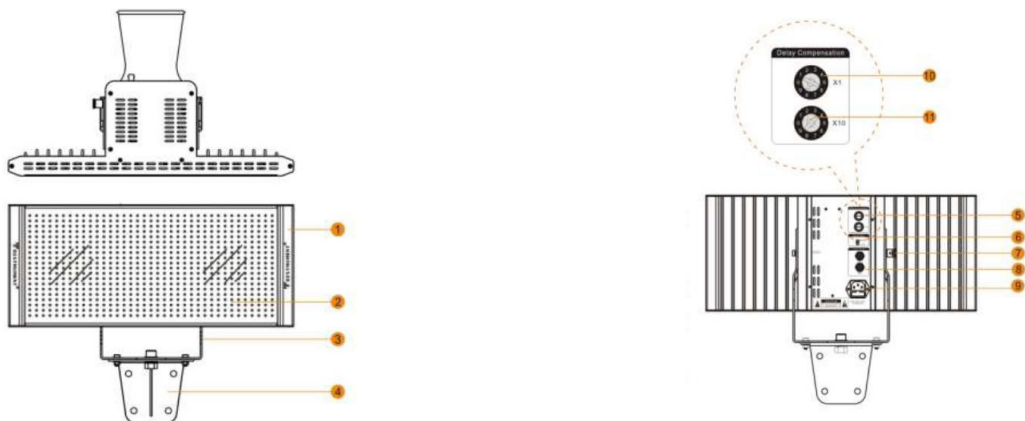

- 1) Aluminium alloy front panel
- 2) Radiating lamp panel
- 3) Bracket
- 4) Tray
- 5) Delay compensation x1 and delay compensation x10
- 6) Output power selection switch

- 7) Radiation angle adjustment handle
- 8) Coax signal input / output
- 9) POWER connector, connect AC 100 ~ 120V, 8A / AC 220 ~ 240V, 5A 50, 60 Hz power supplier
- 10) Delay compensation scale
- 11) Delay compensation stirring knob

Installation of infrared radiator

For position planning, please read section to understand and consider every aspect of infrared distribution system.

The rectangular footprint

To determine the optimal number of infra-red radiators needed to have complete coverage of a conference venue can only be done by performing a site test. However, estimation can be done by «guaranteed rectangular footprints». The rectangular footprint is smaller than the actual footprint. Figure shows a negative «offset» X because the radiator is actually mounted beyond the horizontal point at which the rectangular footprint starts.

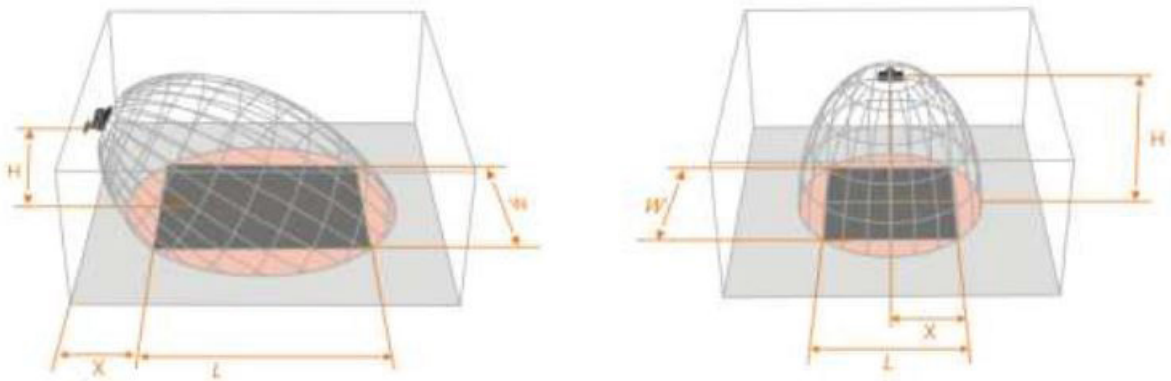

The mounting height is the distance from the reception level and not from the floor to the radiator. Usually, the distance from the reception level to the floor is 1 m approximately. Guaranteed rectangular footprints can also be calculated with the footprint calculation tool (available on the documentation CD-ROM) The given values are for one radiator only, so do not take into consideration the beneficial effects of overlapped footprints and reflections. For up to 4 carriers, a common calculation is given that if the receiver can pick up the signal from adjacent radiators the distance between these radiators can be increased by a factor 1.4 approximately.

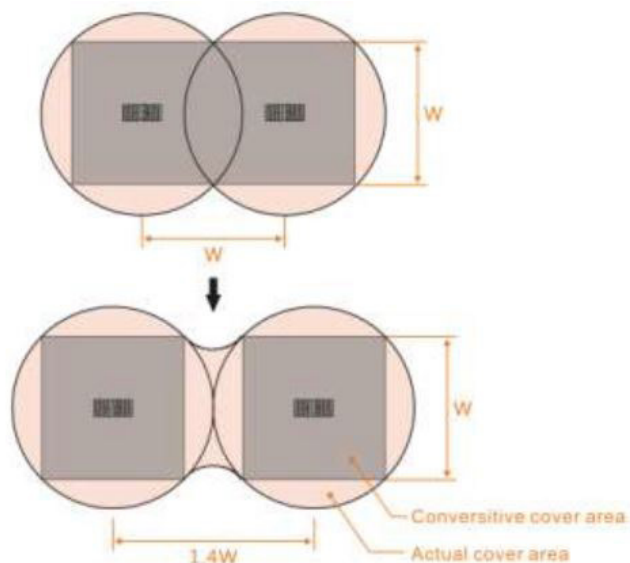

Planning radiators

Plan the radiators by following procedure.

1. Decide the positioning of the radiators by the recommendations in section 2.3.
2. Decide the applicable rectangular footprints by consulting the table or calculating with the footprint calculation tool.
3. Draw a picture of the rectangular footprints in the layout of the room.
4. If the receiver can pick up the signals of from neighboured radiators in some areas, determine the overlapped effect and draw the picture of the footprint enlargement(s) in the layout of the room.
5. Check whether it have sufficient coverage with the radiators at the intended positions.
6. If not, add additional radiators

Placement of infrared radiator

Signal delay differences can occur because of the differences in the cable length from the main unit to each radiator. In order to avoid the risk of black spots, use equal cable length from main unit to radiator if possible.

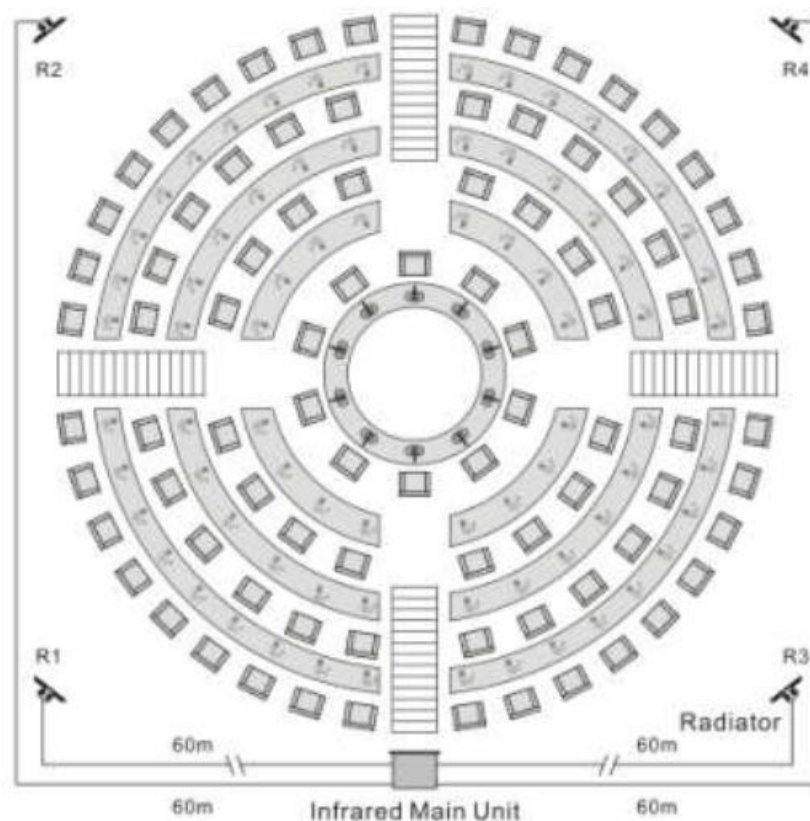

If radiators are connected hand by hand, the cabling between each radiator and the transmitter should be as symmetrical as possible. The differences in cable signal delays can be compensated with the signal delay compensation switches on the radiators.

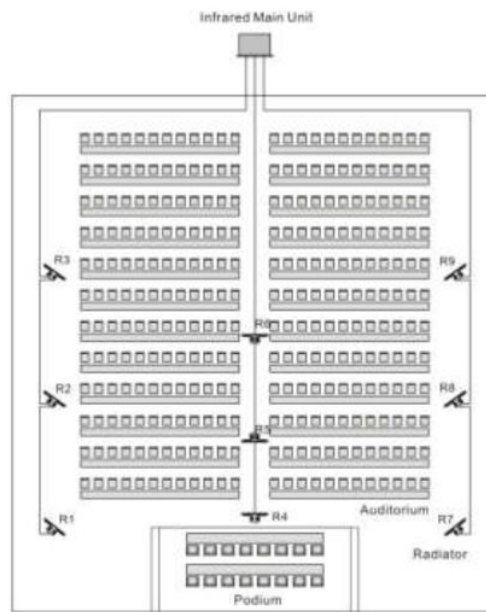

Mounting

The radiator can be permanently installed on the wall, under a ceiling or balcony by bracket. The mounting angle can be adjusted for optimal coverage through angle adjust handle. A separate bracket is optional for wall mounting and a floor stand can be used for nonpermanent installation.

Note : When in operation, the radiators may feel warm. It is normal and does not indicate a radiator fault or malfunction.

Warning : Always make sure that natural airflow is not obstructed by ceilings, walls etc. When determining the position of the radiator. Leave plenty of space around the radiator to prevent overheating.

Mounting on a floor stand

Fix the bracket of the radiator into the top of the floor stand with screw. The bracket is supplied with both metric and inch screw plate and is compatible with most stand floor stands.

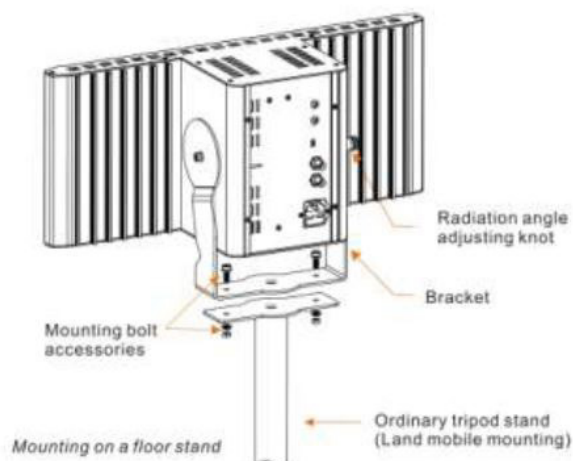

Wall mounting

A separate bracket is optional for wall mounting. The bracket can be fixed on to the wall by 4 screws.

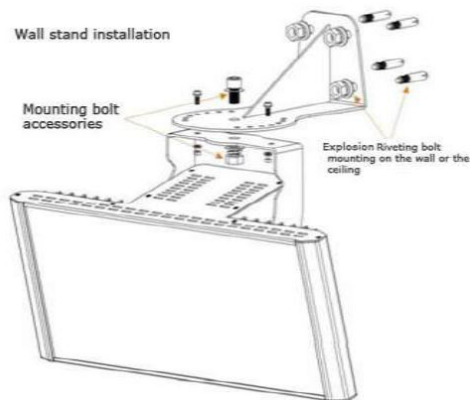
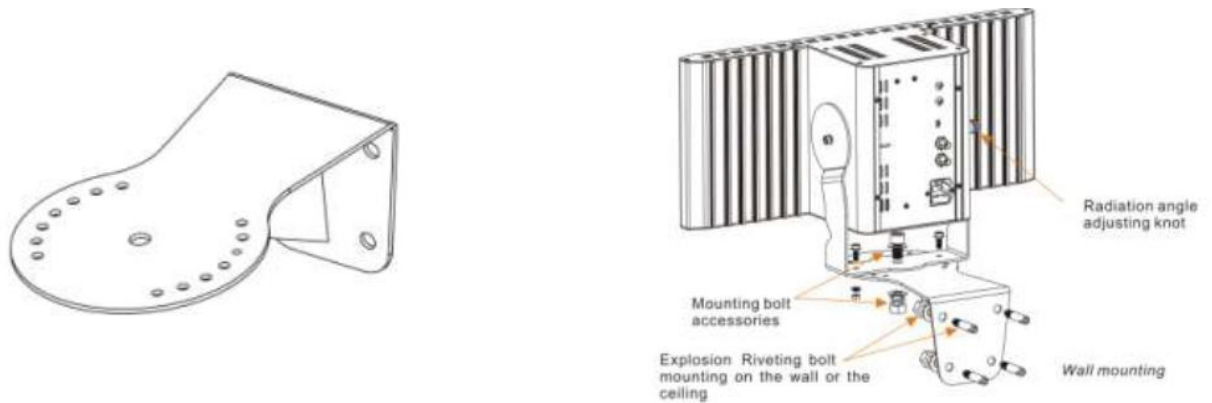

Ceiling mounting

The radiator can be fixed to the ceiling by using the built-in bracket. Please make sure to have enough space for a proper air flow around the radiator when select ceiling mounting. In most cases, a ventilator is needed to prevent overheating.

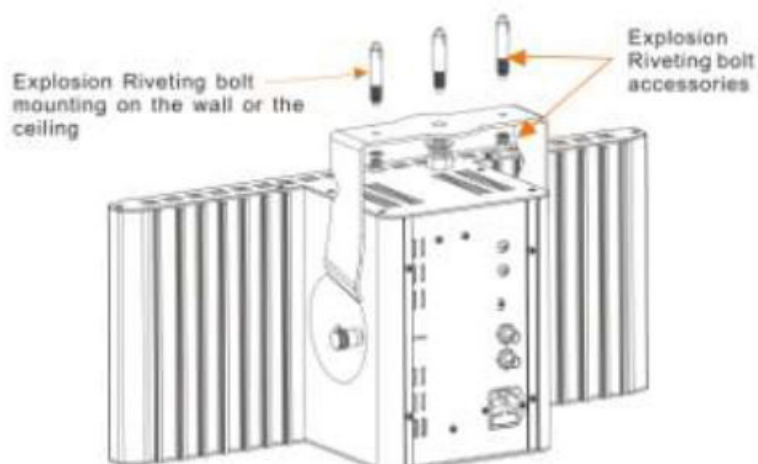

Mounting on horizontal surface

If the radiator has to be installed on a horizontal plane (e.g. on the top of an interpreter booth), the distance between the radiator and the plane should be at least 4 cm to ensure enough airflow around the radiator. If not, switch the radiator to half power. If the radiator is working at full power on top of an interpreter booth, the ambient temperature should not exceed 35°C.

Installation finishing

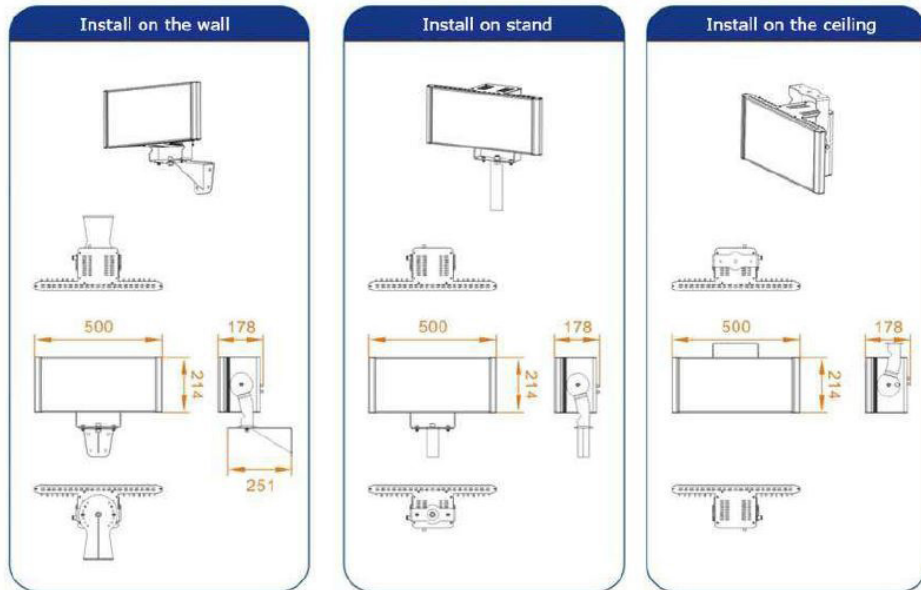

Installation of preventing dropping cord

To prevent the dropping of radiator which is caused by accident, it must install a preventing dropping cord.

One end is hooked on to slotted hole of radiator back panel. The other end sucker is fixed on well by screw and nut.

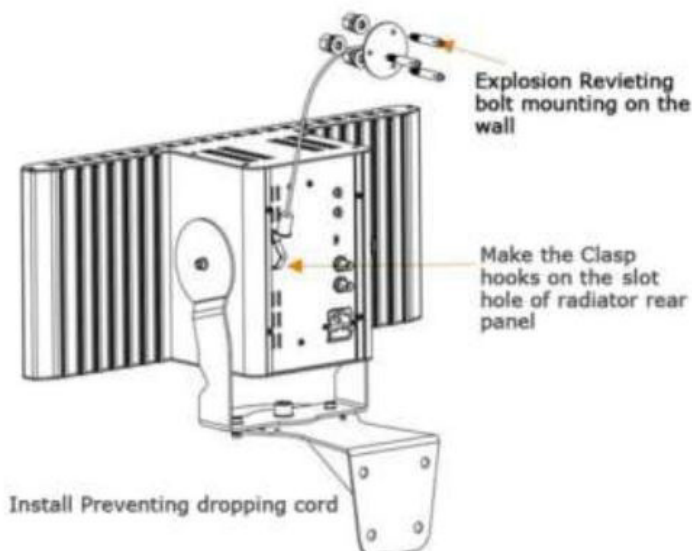

Connecting of radiators

There are six HF signal output interfaces on the main unit. Each one can connect up to 30 radiators by “hand by hand”. The radiators are connected with RG-59 cables. The maximum cable length per output is 900m.

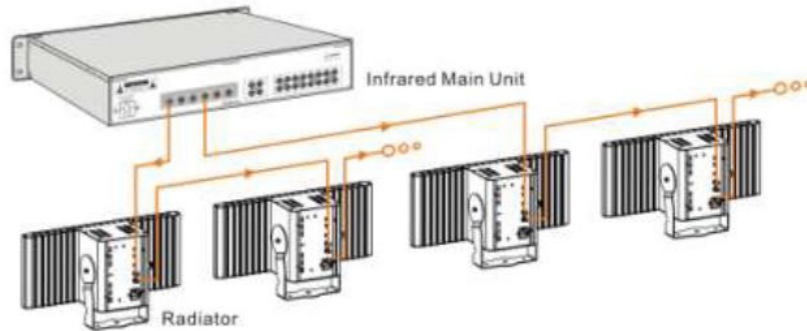

Output power selection

The radiator can be switched to half power output. This is usually done when full power output is not needed, e.g. when a portable system is used in a small venue. Switch a radiator to half power if an adequate airflow cannot be guaranteed, e.g. if the radiator is mounted on the top of an interpreter booth. Reduce the power as often as possible to save energy and to increase the lifetime of the radiator.

Setting the radiator delay switches

Signals picked up by the receiver from two or more radiators can cause black spots due to delay differences.

Signal delays reasons

- Cable signal delay, caused by the cable transporting the signal from the transmitter to the radiator.
- Radiation signal delay, caused by the air transporting the signal from the radiator to the receiver.

To compensate the signal delay differences, the delay of each radiator can be increased. Signal delays can be set with the delay switch situated at the side of the radiator. It has a digital display showing the current compensation value. The switch can be adjusted from “00” (“00” means no compensation) to “99”.

Compensation time is calculated by multiplying 25 ns with the switch set value. Thus compensation time varies between 25 ns and 2475 ns (99 x 25)

Delay compensation
Parameter setup
description:

As shown, Delay
compensation
parameter is 18

Gap on the X1 knot
pointing to a number
means Units digit

Gap on the X10 knot
pointing to a number
means tens digit

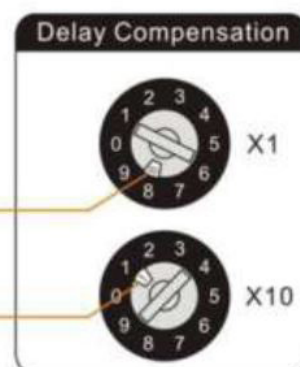

In most cases the cable signal delays can be calculated manually using in addition the delay switch calculation tool.

How to calculate the delay switch positions manually for systems with one, two or more transmitters will be described in the next sections. Refer to the delay switch calculation tool for information how to do to get a computed value for the delay switch position.

There are no cable signal delays in systems with only one transmitter and radiators directly connected to the transmitter with cables of identical length. The delay switches on all radiators are to be set to zero. Subsequently check whether to compensate for radiation signal delay. If the cable lengths differ from radiator to radiator, the delay switch parameter can be calculated with the formula. Take signal delay rate as 5.6 ns/m as example :

$$X = [(L_{MAX} - L) \times 5.6] / 25$$

- X : Delay compensation parameter, displayed on LCD
- L_{MAX} : Maximum cable length in the considered chain
- L : Cable length between transmitter and radiator

Use the following procedure to determine the delay switch position based on cable lengths :

1. Measure the cable length L between the transmitter and every single radiator;
2. Determine the maximum cable length L_{MAX}. For each radiator calculate the cable length difference value L_{MAX}-L;
3. To obtain the cable signal delays for each radiator, multiply the cable length difference of each radiator with the cable signal delay per meter;
4. Divide the calculated signal delay difference by 25. The rounded off figure is the signal delay switch position for the radiator;
5. If applicable, add delay switch positions for radiators under a balcony;
6. Set the delay switches to the calculated switch positions.

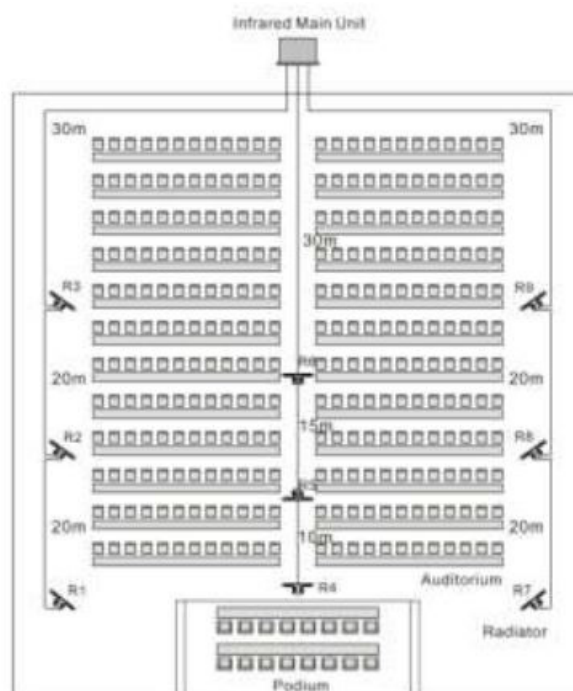

Radiator number	Total cable length L (m)	Cable length difference LMAX*-L(m)	Cable signal delay per meter (ns/m)	Signal delay difference (ns)	Delay switch position
R1	30+20+20=70*	70*-70 = 0	5.6	0*5.6 = 0	0/25 = 0
R2	30+20=50	70*-50 = 20	5.6	20*5.6 = 112	112/25 = 4.48 ≈4
R3	30	70*-30 = 40	5.6	40*5.6= 224	224/25 = 8.96 ≈9
R4	30+15+10=55	70*-55 = 15	5.6	15*5.6 =84	84/25 = 3.36 ≈3
R5	30+15=45	70*-45 = 25	5.6	25*5.6 = 0	0/25 = 0
R6	30	70*-30 = 40	5.6	40*5.6= 224	224/25 = 8.96 ≈9
R7	30+20+20=70*	70*-70 = 0	5.6	0*5.6 = 0	0/25 = 0
R8	30+20=50	70*-50 = 20	5.6	20*5.6 = 112	112/25 = 4.48 ≈4
R9	30	70*-30 = 40	5.6	40*5.6= 224	224/25 = 8.96 ≈9

Note : The used cable signal delay per meter is only serving as an example. For your calculation, use the actual signal delay per meter value specified by the cable manufacturer.

System with more than 4 carriers and a radiator under a balcony.

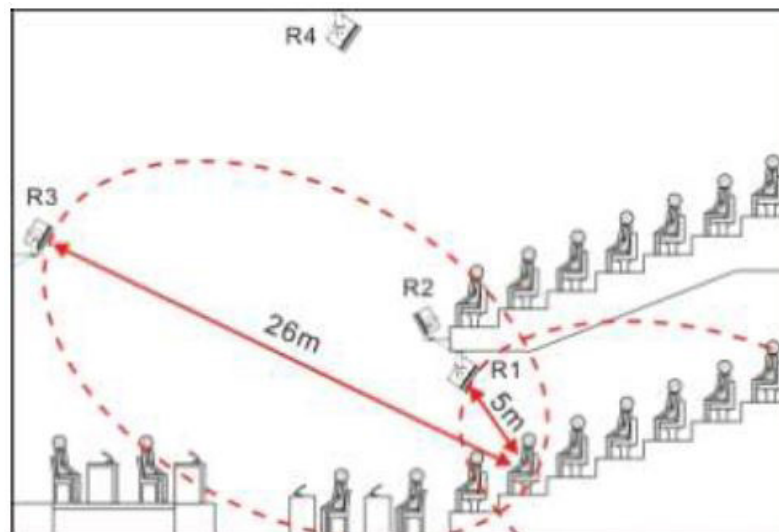

This figure shows a radiation signal delay which needs to be compensated. For a system with more than four carriers, add one delay switch position per 8 meters difference in signal path length to the radiators that are closest to the overlapping coverage area. The signal path length difference is 12 meter, in the previous figure. Add one delay switch position to the switch position(s) for the radiator(s) under the balcony.

LINEARCOM3000



Linear Technologie • 11 rue du Puits Rochefort • 42 100 Saint-Etienne
Tél: +33 (0)4 77 81 49 49 • Fax: +33 (0)4 77 81 49 40 • www.lineartech.fr