

LINEARCOM3000

INFRARED RECEIVER 8 CHANNELS LC3.IRRC08

Operation manual



TABLE OF CONTENTS

1. Safety operation.....	Page 3
2. System introduction.....	Page 4
3. Infrared receiver unit.....	Page 9

1. SAFETY OPERATION

Firstly, thank you very much for using LINEARCOM3000 conference system. To make sure safety of equipment and user, please read this safety instruction carefully before installing and using and operate seriously according to this manual. Also please keep this safety instruction for future reference. Notices are as below :

1. Wiring during installation must follow national electric safety standards, national fireproofing regulations and all related local regulations.
2. Protect the power cord from being walked on and do not stack things on the power cord, particularly at plugs.
3. To make sure earth wire connecting well. Do not use 2 - pin plugs. Power supply : 220V 50 Hz.
4. Power supply cords :
 - America, Japan : AC 110V ~ 120V 60 Hz
 - Asia, Europe : AC 220V ~ 240V 50 Hz
5. The packaging of equipment is designed for protecting 1.5 meters dropping but please prevent from stress and shocking during transportation, installation and storing.
6. Do not place the system equipments on too cold or too hot room.
7. Keep good ventilation to protect the machine.
8. Unplug the system during wet weather or when unused for long periods of time.
9. Must unplug the equipment before below operations :
 - Taking down or resetting any part on machine
 - Reconnecting any plug in system
10. Do not disassemble or maintain the product by non-authorized personnel to avoid accident or damage. Warning label is as below :

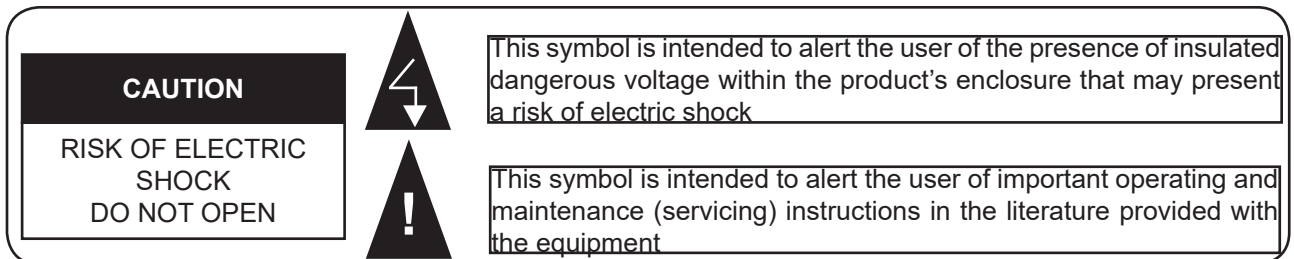

11. Prevent from any chemicals or liquid.
12. Please check all the connections completely before turning on. Check the set-up of main unit before usage.
13. If you find top warning label on product, it means : Do not open the machine cover to avoid electric shock. Also please do not place the useless part in the case. Any trouble, please contact with the authorized personnel.

2. SYSTEM INTRODUCTION

Brief introduction

LINEARCOM3000 is a series product of digital infrared language distribution system. It uses both digital infrared audio transmitting and control technique and an IR digital infrared chip. They own LINEARCOM3000's intellectual property. IRRC08 can be used in simultaneous interpretation systems for multi-language conferences.

In simultaneous interpretation systems, the interpreter translates the speaker's speech, the translated audio transmits through the conference venue by modulated infrared radiation and the delegates listen to wanted language by infrared receiver via earphone.

The system can also be used for other audio signal distribution occasions, such as urgent mode, free mode audio signal output.

This system is compliant to IEC 61603-7 (international standard of digital infrared transmission) and IEC60914 (conference systems-electrical and audio requirements, same as domestic standard GB/T 15381-94), moreover, it is compatible with other IR systems, compliant to IEC 61603-7. Parts of IEC 61603 are used in this manual for a better understanding of both theory and technique of the system.

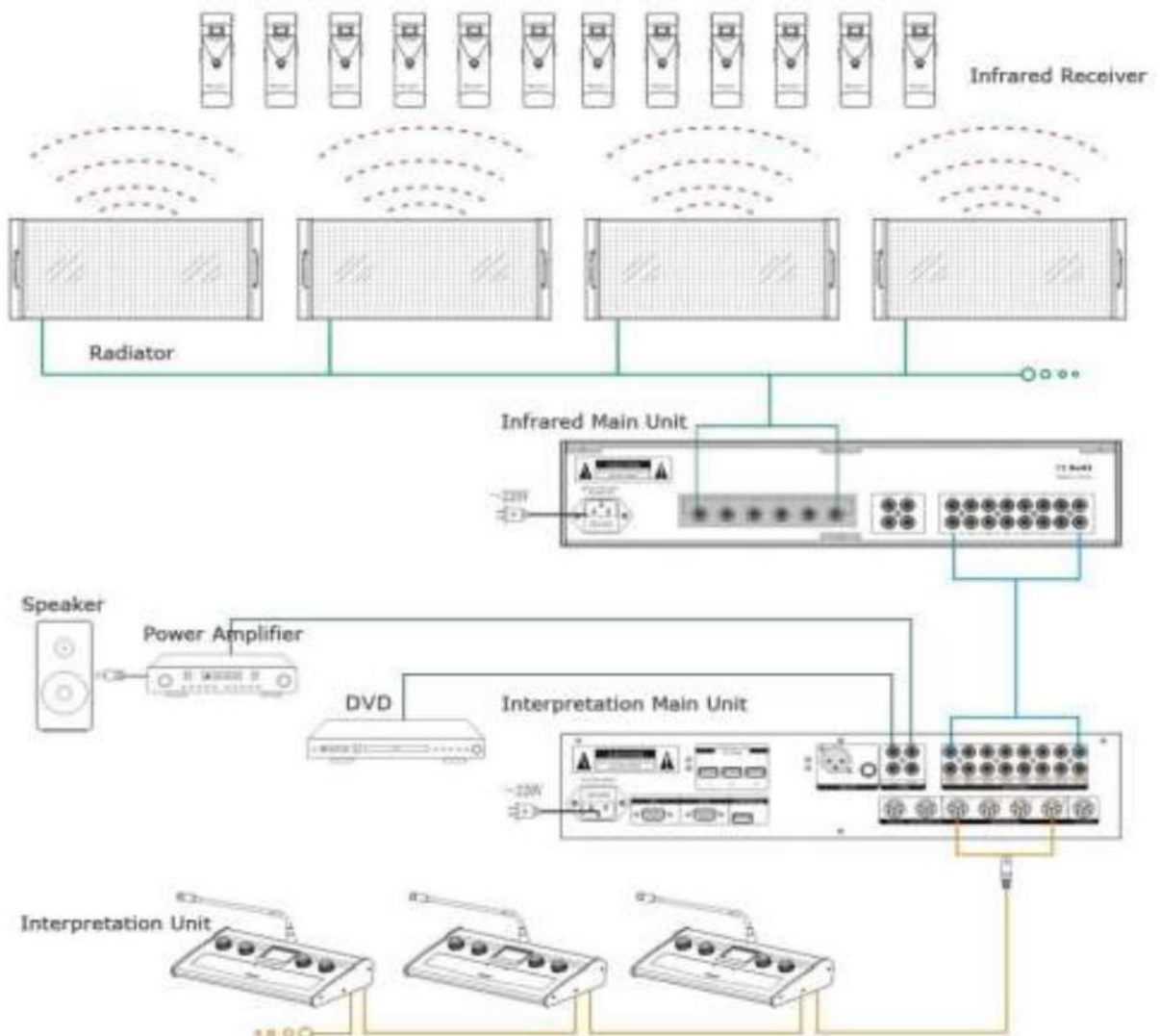

System composition

The system consists of a number (N) of audio sources, either analogue or digital, which are connected to a transmitter. The transmitter processes the audio signals into an electrical output to feed the infrared radiator. The infrared signal is received by the infrared receiver that processes the signal and outputs an audio signal and/or associated data.

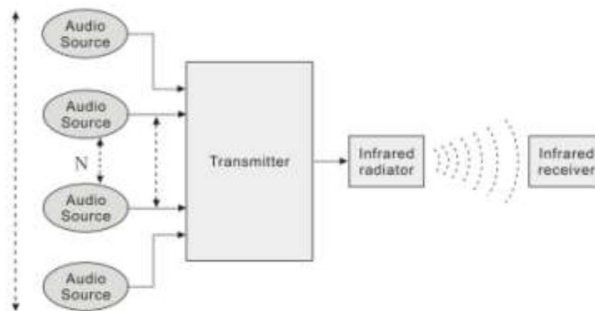

System radiation signal

IRR25 uses high frequency carrier signals (typically 2~8 MHz) to prevent interference by modern light sources. Fully digital audio processing guarantees a constant high audio quality. The signal processing in the main unit consists of the following main steps :

1. Code : Each analogue audio channel is converted to a digital signal; the digital signals are compressed to increase the amount of information that can be distributed on each carrier (compression ratio is related to required audio quality); groups of up to 4 digital signals are combined into a digital information steam. Extra fault algorithm information is added. This information is used by the receivers for fault detection and correction.
2. Modulation : A high frequency carrier signal is phase-modulated with the digital information stream by digital wireless base station digital modulation technique.
3. Filter
4. Magnify
5. Radiation : Up to 8 modulated carrier signals are combined and sent to the IR radiators, which convert the carrier signals to modulated infrared light.

In the IR receivers, a reverse processing is used to convert the modulated infrared light to separate digital audio channels.

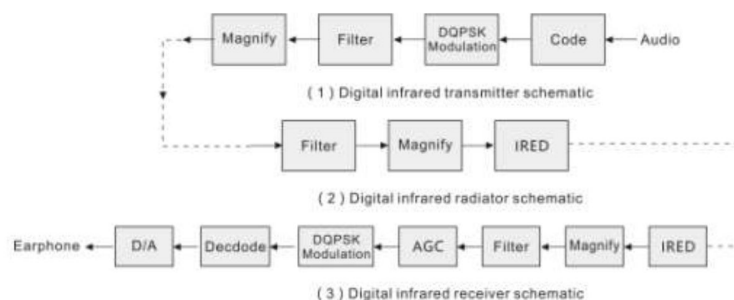

Carriers

System is transmitting within the 2 ~ 8 MHz frequency band. It can transmit up to 8 different carrier signals (depending on the transmitter type) Carriers 0 to 5 are according to IEC 61603-7.

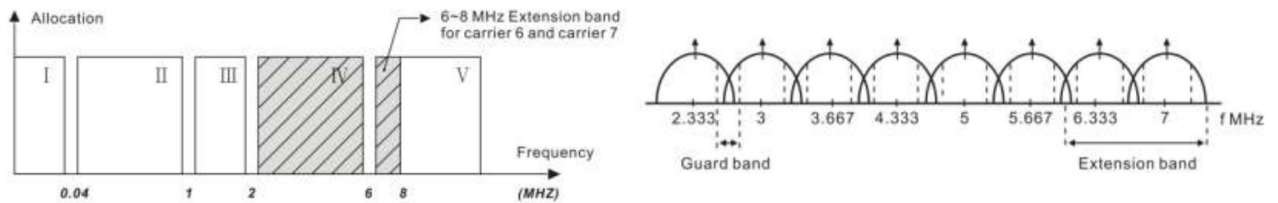

Aspects of infrared distribution

A good digital infrared language distribution system ensures that all delegates in a conference venue receive the distributed signals without disturbance. This is achieved by using enough and well positioned radiators, so that uniform IR signal with adequate strength can be received at any place of the conference venue.

When planning an infrared distribution system several aspects influencing the uniformity and quality of the infrared signal should be considered. These are discussed in the next sections.

Ambient lighting

IRRC08 can be operated without any problem even if fluorescent lamps (with or without electronic ballast or dimming facility) such as TL lamps or energy saving lamps are switched on.

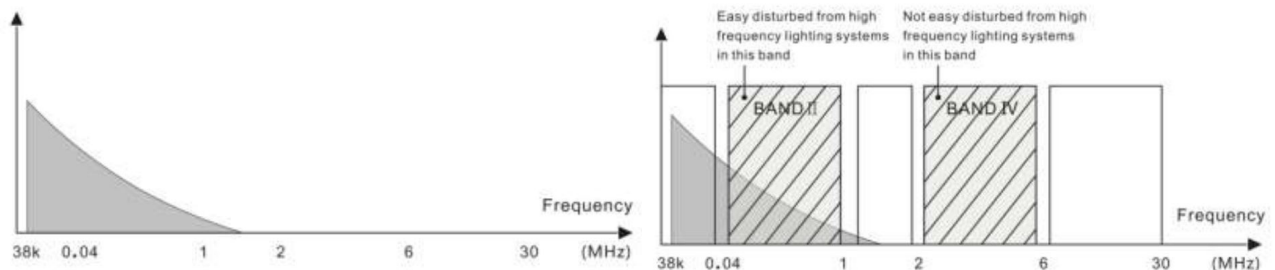

For venues with large, unscreened windows, more radiators should be added. For outdoor use, a site test will be required to determine the required amount of radiators. With sufficient radiators, the receivers will work well, even in bright sunlight.

Objects, surfaces and reflections

Just like visible light, infrared radiation is reflected from hard surfaces and refracted by hyaloid (glassy or transparent appearance) objects. Both objects in the conference venue and structure of the walls and ceilings will influence the distribution of infrared light.

Infrared radiation is reflected from almost all hard surfaces. Smooth, bright or shiny surfaces reflect well. Dark or rough surfaces absorb a large part of the infrared energy. Normally surfaces opaque to visible light are also opaque to infrared radiation. Shadows from walls and furniture will influence the transmission of infrared light. This can be solved by using a sufficient quantity of radiators. They should be positioned in a manner to provide an infrared field strong enough to cover the whole conference area. Take care not to direct radiators towards uncovered windows, or most of this radiation will be lost.

The direction and sensitivity of receiver unit

The sensitivity of a receiver is at its best when it is aimed directly towards a radiator. To minimize the disadvantage of this aspect, IRRC08 receiver adopts an ingenious structural design with peculiar 270° ultra wide angle to get perfect IR capture and sound quality at any disposition.

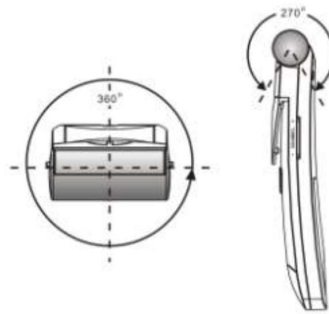

The coverage area of radiator

The number of transmitted carriers and the output power of the radiator determine the coverage area of a radiator. The total radiation energy of a radiator is distributed over transmitted carriers. The coverage area becomes proportionally smaller if more carriers are used. The receiver requires a strength of the IR signal of 4 mW / m² per carrier to work well (resulting in an 80 dB S/N ratio for uninterrupted audio channels)

The cross section of the 3 dimensional radiation with the reception level of participants is the footprint (the dark grey area in figure 2.9 to figure 2.10) In this area, the direct signal is strong enough to ensure proper reception when the receiver is directed towards the radiator. The size and position of the footprint depends on the mounting height and the angle of the radiator.

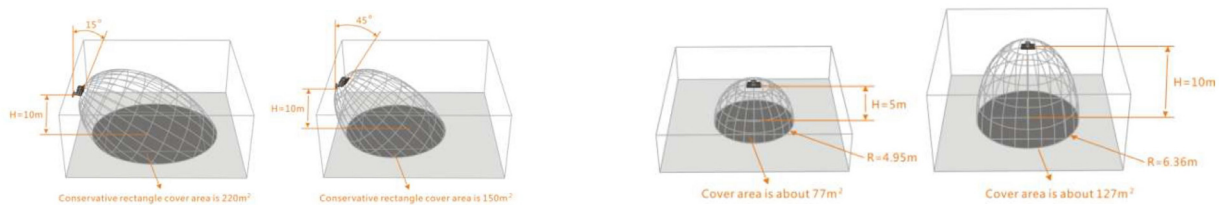

Area contrast of different installation height

Area contrast between 15° and 45° to the ceiling

Positioning the radiators

Because infrared radiation can reach a receiver directly and / or via diffused reflections, it's important to take this into consideration when installing the radiators. For best reception quality, receivers should pick up direct infrared radiation. In addition reflections will improve the signal reception. In big conference halls, infrared signal will be blocked by the people in front of the receiver. For that reason the radiator should be installed at an appropriate height, usually not below 2.5 meters.

For concentrically arranged conference venues, radiators located high up and faced to the center from every angle can cover the area very efficiently. If the direction of the receiver changes, e.g. changing seat direction, the radiators can be installed in the corners of the room.

In the case the seating is always directed towards the IR emitting source, there are no radiators needed at the back.



If the path of the infrared signals is blocked, e.g. under balconies, at least one additional radiator is needed to cover the 'shaded' area.

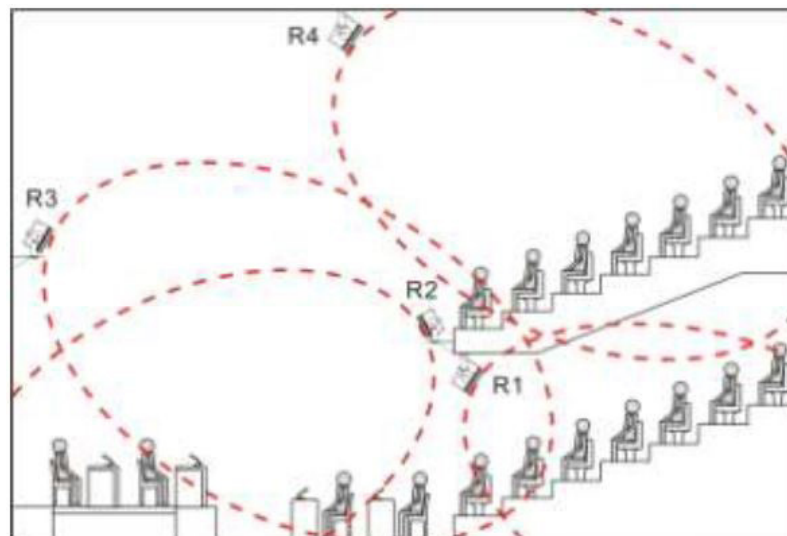

Overlapped footprints and multi-path effect

If footprints of two radiators overlap, the total coverage area maybe larger than the sum of the two separate footprints. In an area with overlap effect, the individual radiation signals of two radiators are added, resulting in an increase of the radiation intensity, larger than the required intensity.

However, due to the differences in the delays of the signals from two or more radiators, the signals may cancel out each other (multi-path effect). In a worst-case situation, loss of reception at some positions (black spots) may be the consequence.

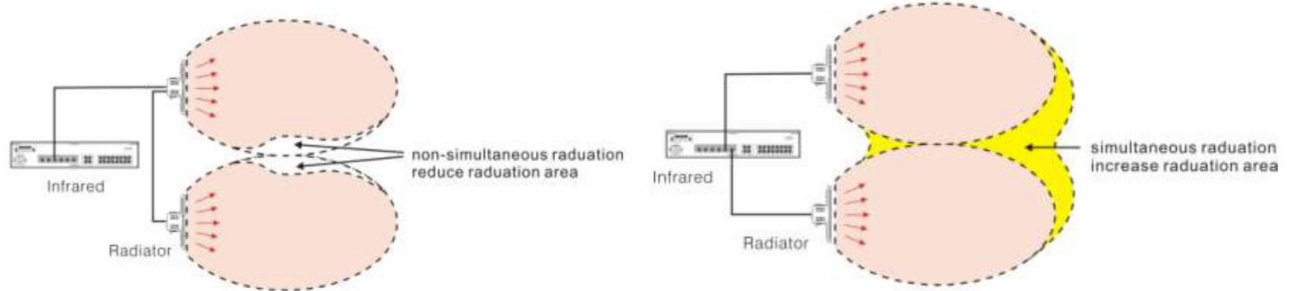

Increased coverage area caused by added radiation power **Reduced coverage area caused by differences in cable signal delay**

The lower the carrier frequency, the less susceptible the receiver is for differences in signal delays.

The signal delays can be compensated by adjusting the delay compensation switches on the radiators.

3. INFRARED RECEIVER UNIT

LINEARCOM3000 infrared receiver unit can receive up to 32 language channels. Both rechargeable Ni-HM battery and disposable battery can be used. The receiver is equipped with channel selector, volume control, power switch, Ø 3.5 mm stereo earphone jack. A LCD displays channel number, received signal intensity, battery capacity and volume.



Function and feature

- Steam line design, accord with clay engineering.
- Adopt full digital conference technology, compliant to IEC61603-7 and IEC 60914 international standard.
- Compatible with the infrared simultaneous interpretation system which is compliant to IEC61603-7.
- New digital lock function, totally stop outside disturbing and wiretapping.
- Adopt 2-8 MHz, infrared receiver will not be disturbed by high frequency driving light source.
- 4CH, 8CH, 16CH, 32CH audio channels.
- When without earphone, press «Power» key, LCD could display last channel No and battery.
- LCD display, can display channel no, signal intensity, volume and battery power.
- It can adjust the volume individually and has 270° reception angle.

LINEARCOM3000

- Adopt high capacity rechargeable lithium battery. It will have no power consumption under power off or disconnecting earphone.
- In the district of infrared signal, quantity of receivers is unlimited.
- Shield automatically unwork channels; working channel quantity is same as available channel quantity.
- Channel resolution and SNR reach to 102 dB; it can perfectly resolve crosstalk and noise ect normal problems. Working with mute function (it will mute automatically, when signal too lower, have no noise), listeners have comfortable, natural and high quality audio finishing.
- Receivers have guard function, built-out guard advice equipment.
- 2 hanging modes, gallus mode and clip mode. It can be hold in pocket or hanged, even taken on desk.
- Extra low power consumption. Can continue to work for 30 hours if you use our original lithium ion battery. Also you can use alkaline battery.
- A charge box can accommodate 36 / 72 / 108 receivers. Convenient to transport and carry.
- 3.5 mm stereo earphone output.

Technical parameter of digital infrared receiver

Channel	8 CH
Modulation mode	Digital wireless base station
Carrier frequency	2-8 MHz
Audio processing	IR-DSP
Distortion	<0.2%
SNR	>102 dB
Working voltage	3.7V
Earphone load	320 hm 250 mW
Earphone output	3.5 mm socket x1
ON	Plug earphone and press "ON/OFF" key
OFF	Disconnect the earphone / no signal shut off automatically / press «Power» key 2 seconds to turn off it
OFF delay	Disconnect the earphone in 0 second / no signal about 2 minutes
Battery	Lithium battery or alkaline battery
Battery life	30 hours
LCD display	Channel, signal, power weak reminder
Dimension	155 x 49 x 27 mm
Weight	0.1 kg
Color	Black, grey

Infrared receiver schematic diagram

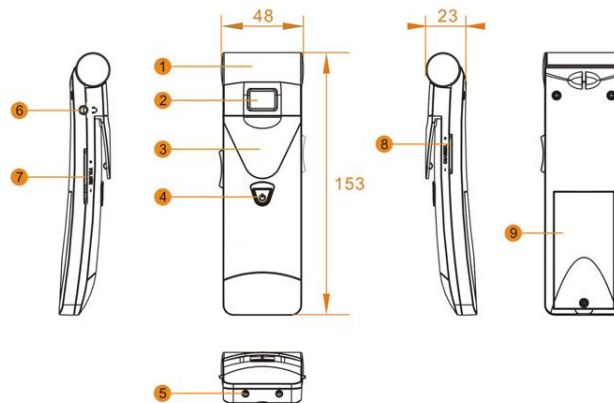

Functions and indications

1. Infrared red filtering glass
2. LCD
3. Pocket clamp
4. Power switch
5. Charging contacts
6. Earphone jack
7. Volume selector
8. Channel selector
 - "VOLUME+" is volume increasing
 - "VOLUME-" is volume decreasing
 - "CHANNEL+" is channel increasing
 - "CHANNEL-" is channel decreasing
9. Battery box : 3.7V rechargeable battery

Note : When the receiver is not used, please disconnect the earphone. This ensures that the receiver is totally switched-off and no energy is consumed from the batteries or the battery pack.

Operation

The receiver only works if an earphone is connected and the receiver switches to stand-by state. Push shortly on the power switch button to switch on the receiver. The channel number is shown on the LCD. The channel can be changed with the channel selector. Channel number is in accordance with the channel configuration set up in the main unit.

When working, battery icon and antenna icon will be displayed on LCD to indicate current battery and signal status. A battery symbol  is visible on the display when the batteries or the battery pack is almost empty and needs recharging but it still might work for 2 hours. When the signal is interrupted for a short time, the receiver mutes the earphones output. If the IR receiver does not get an adequate IR signal for more than 2 minutes (e.g. when a delegate leaves the conference room), the receiver automatically switches to stand-by state. The volume can be adjusted and displayed on LCD (the range is from 0 to 31) If the earphone is disconnected, the receiver is automatically switched off.

The infrared receivers are operable either with disposable batteries (2 x AA alkaline cells) or with a rechargeable battery pack. Install the batteries or the battery pack with the correct polarity, as indicated in the battery compartment. A separate connection cable is required if a battery pack is used. The charging circuitry will not work if this cable is missing, preventing thus also charging of disposable batteries by mistake. The battery pack is equipped with a temperature sensor to prevent overheating during charging.

Note : When without earphone, press «Power» key, LCD could display last channel No and battery.

Testing the coverage area

To make sure that the whole area is covered with adequate IR radiation and avoiding thus black spots, an extended reception quality test should be done. The test can be done in two ways :

- **Testing during installation**

1. Check that all radiators are connected and powered up;
2. Set the main unit in the test-mode. For each channel, a test tone frequency will be transmitted;
3. Set a receiver to the highest available channel and listen to the received signal through the headphones;
4. Test all positions and directions.

- **Testing all positions and directions**

Walk around the conference venue under the test mode of the main unit or the receiver; test every position where the signal must be received. If an area is detected as having bad reception or even no reception at all, two main causes should be taking into consideration :

01 bad coverage : The receiver cannot pick-up adequate infrared radiation. This may be because the tested position is out of the footprint of the installed radiators or the radiation is blocked by obstacles such as a column, an overhanging balcony or other large objects. Check whether you used the correct footprints for the system design or not. Check if the radiators are used which are switched to half power operation by mistake. If bad reception is caused by a blocked radiation path, try to remove the blocking obstacle or add an extra radiator to cover the shaded area with more IR energy.

02 black spots : IR signals coming from two radiators may cancel out each other (multi-path effect) when reaching the receiver. Bad reception only happens on some special path. Multi-path effect is confirmed being the cause of bad reception if the bad signal received by the receiver is improving the instant a radiator is a) changing its direction b) shaded -off or simply switched-off. IR radiation, reflected from a surface with a high reflectivity may also cause multi-path effect.

Check that the signal delay compensation switches on the radiators are set to the correct value. Check the system design. If necessary, reduce the distance between the two radiators that cause the problem and/or add an extra radiator.

Please note that due to the physical characteristics of the signal distribution, it is not possible to avoid multi-path effects completely.

LINEARCOM3000



Linear Technologie • 11 rue du Puits Rochefort • 42 100 Saint-Etienne
Tél: +33 (0)4 77 81 49 49 • Fax: +33 (0)4 77 81 49 40 • www.lineartech.fr