

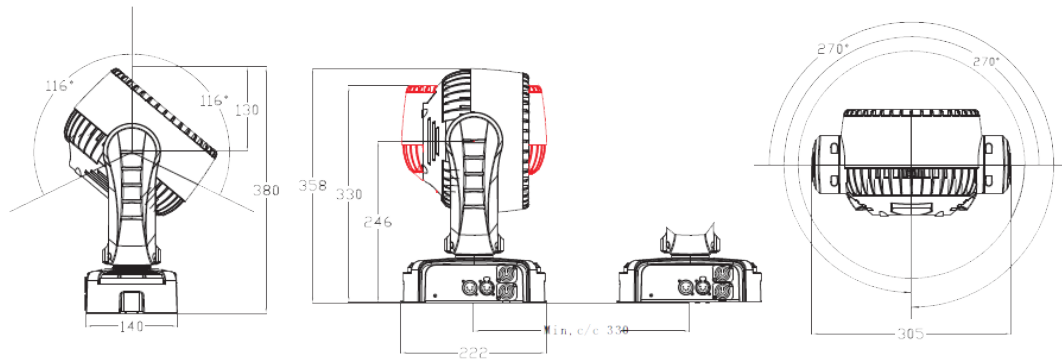

TABLE OF CONTENTS

1. Dimensions.....	Page 3
2. Safety information.....	Page 3
3. Fixture overview.....	Page 5
4. Introduction.....	Page 6
5. AC power.....	Page 6
6. Data link.....	Page 8
7. Physical installation.....	Page 9
8. Setup.....	Page 10
9. Operation and effects.....	Page 13
10. Service and maintenance.....	Page 15
11. DMX protocol.....	Page 17
12. FX: pre-programmed effects.....	Page 22
13. LEE colors and RGB equivalents.....	Page 24
14. Onboard control menus.....	Page 25
15. Display messages.....	Page 26
16. Specifications.....	Page 27

1. DIMENSIONS

All dimensions are in millimeters.



2. SAFETY INFORMATION



WARNING!

Read the safety precautions in this section before installing, powering, operating or servicing this product.

The following symbols are used to identify important safety information on the product and in this manual :



DANGER!
Safety hazard.
Risk of severe injury or death.



DANGER!
Hazardous voltage. Risk of lethal or severe electric shock.



WARNING!
Fire hazard.



WARNING!
LED light emission.
Risk of eye injury.



WARNING!
Burn hazard.
Hot surface.
Do not touch.



WARNING!
Wear protective eye wear.



WARNING!
Refer to user manual.



Warning! Risk group 3 (high risk) LED product according to EN 62471. Do not look into the beam at a distance of less than 8.3 meters (27 ft. 3 inches) from the front surface of the product. Do not view the light output with optical instruments or any device that may concentrate the beam.



This product is for professional use only. It is not for household use. This product presents risks of severe injury or death due to fire and burn hazards, electric shock and falls.



Read this manual before installing, powering or servicing the fixture, follow the safety precautions listed below and observe all warnings in this manual and printed on the fixture. If you have questions about how to operate the fixture safely, please contact your supplier.

Protection from electric shock

- Disconnect the fixture from AC power before removing or installing any cover or part and when not in use.
- Always ground (earth) the fixture electrically.
- Use only a source of AC power that complies with local building and electrical codes and has both overload and ground-fault (earth-fault) protection.
- Before using the fixture, check that all power distribution equipment and cables are in perfect condition and rated for the current requirements of all connected devices.
- Power input and through put cables must be 3-conductor, rated 20 A minimum, 1.5 mm² (16 AWG) minimum conductor size, power input and through put cables must be 3-conductor, rated 20 A minimum, 1.5 mm² (16 AWG) minimum conductor size, extra hard usage type (ST or equivalent) The cable must be heat-resistant to 90° C (194° F) minimum.
- Use only neutrik powercon NAC3FCA cable connectors to connect to power input sockets. Use only neutrik powercon NAC3FCB cable connectors to connect to power throughput sockets.
- Isolate the fixture from power immediately if the power plug or any seal, cover, cable, or other component is damaged, defective, deformed, wet or showing signs of overheating. Do not reapply power until repairs have been completed.
- Do not expose the fixture to rain or moisture.
- Refer any service operation not described in this manual to a qualified technician.
- Socket outlets used to supply LYA200 fixtures with power or external power switches must be located near the fixtures and easily accessible so that the fixtures can easily be disconnected from power.



Protection from burns and fire

- Do not operate the fixture if the ambient temperature (Ta) exceeds 40°C (104°F)
- The exterior of the fixture becomes hot during use. Avoid contact by persons and materials. Allow the fixture to cool for at least 10 minutes before handling.
- Keep all combustible materials (e.g. fabric, wood, paper) at least 100 mm (3.9 inch) away from the head.
- Keep flammable materials well away from the fixture.
- Ensure that there is free and unobstructed airflow around the fixture.
- Do not illuminate surfaces within 200 mm (7.9 ins.) of the LYA200.
- Do not attempt to bypass thermostatic switches or fuses.
- If you relay power from one fixture to another using power throughput sockets, do not connect more than ten LYA200 fixtures in total to each other in an interconnected chain.
- Connect only other LYA200 fixtures to LYA200 power throughput sockets. Do not connect any other type of device to these sockets.
- Do not stick filters, masks or other materials onto any optical component.
- Do not modify the fixture in any way not described in this manual.



Protection from injury



- Do not look continuously at LED from a distance of less than 8.3 meters (27 ft. 3 inches) from the front surface of the fixture without protective eye wear such as shade 4-5 welding goggles. At less than this distance, the LED emission can cause eye injury or irritation. At distances of 8.3 meters (27 ft. 3 inches) and above, light output is harmless to the naked eye provided that the eye's natural aversion response is not overcome.
- Do not look at LED with magnifiers, telescopes, binoculars or similar optical instruments that may concentrate the light output.
- Ensure that persons are not looking at the LED from within 8.3 meters (27 ft. 3 inches) when the product lights up suddenly. This can happen when power is applied, when the product receives a DMX signal, or when SERVICE menu items are selected.
- Fasten the fixture securely to a fixed surface or structure when in use. The fixture is not portable when installed.
- Ensure that any supporting structure and / or hardware used can hold at least 10 times the weight of all the devices they support.
- If suspending from a rigging structure, fasten the fixture to a rigging clamp with an M12 bolt screwed into the threaded hole in the center of the base of the fixture. The bolt must protrude at least 20 - 30 mm (0.8 - 1.2 ins.) into the fixture. If the fixture is suspended by any other method, an M12 bolt must be tightened into this hole so that it protrudes at least 20 - 30 mm (0.8 - 1.2 ins.) into the fixture.
- Allow enough clearance around the head to ensure that it cannot collide with an object or another fixture when it moves.
- Check that all external covers and rigging hardware are securely fastened.
- Block access below the work area and work from a stable platform whenever installing, servicing or moving the fixture.
- Do not operate the fixture with missing or damaged covers, shields or any optical component.

3. FIXTURE OVERVIEW

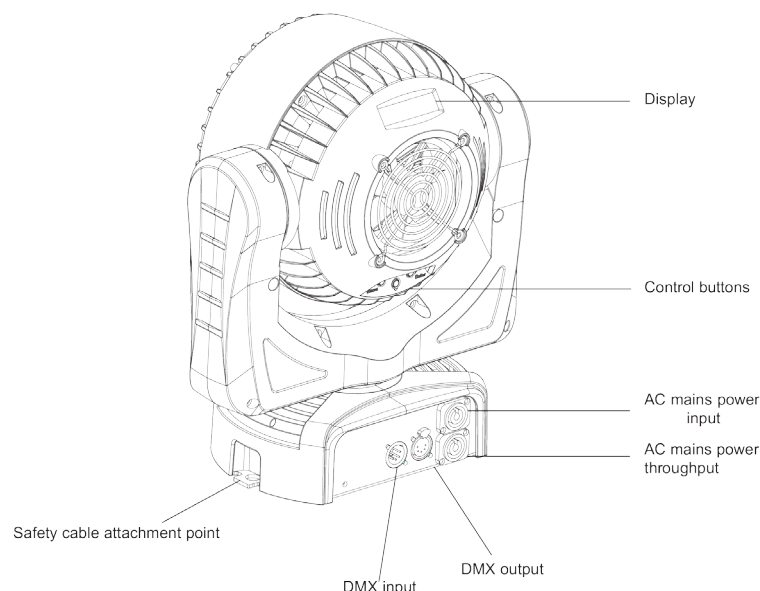

4. INTRODUCTION

This compact LED-based moving-head wash-light features :

- Independent or linked beam (primary LED array) and aura (secondary background LED array) control. Range of pre-programmed independent and synchronized beam and aura effects available via DMX that give instant access to the full potential of the fixture
- Beam RGBW color control with color temperature control
- Aura RGB control
- «Color wheel» color snap beam and aura effects
- On board control panel and backlit LCD graphic display
- Motorized zoom
- Smooth electronic dimming
- Electronic shutter with strobe and pulse effects
- Calibrated and raw modes
- Osram ostar high-power emitters
- DMX control
- 540° pan and 232° tilt ranges

Using for the first time

Warning! Read “Safety information” before installing, powering, operating or servicing the LYA200. Before applying power to the fixture :



- Carefully review “Safety information”.
- Check that the local AC mains power source is within the fixture’s power voltage and frequency ranges.
- See “Power cables and power plug”. Install a neutrik powercon NAC3FCA power input connector on a suitable power cable. If drawing power from a mains power outlet, install a suitable power plug on the power cable.

5. AC POWER

Warning ! Read “Safety information” before connecting the fixtures to AC mains power.

Warning ! For protection from electric shock, the LYA200 must be grounded (earthed) The power distribution circuit must be equipped with a fuse or circuit breaker and ground-fault (earth-fault) protection.

Warning ! Socket outlets or external power switches used to supply the LYA200 with power must be located near the fixture and easily accessible so that the fixtures can easily be disconnected from power.



Important ! Do not insert or remove live neutrik powercon connectors to apply or cut power, as this may cause arcing at the terminals that will damage the connectors.

Important ! Do not use an external dimming system to supply power to the LYA200, as this may cause damage to the fixture that is not covered by the product warranty.

The LYA200 can be hard-wired to a building electrical installation if you want to install it permanently, or a power plug that is suitable for the local power outlets can be installed on the power cable.

Power voltage





Warning! Check that the voltage range specified on the fixture's serial number label matches the local AC mains power voltage before applying power to the fixture.

The fixtures accept AC mains power at 100-240 V nominal, 50/60 Hz. Do not apply AC mains power to the fixture at any other voltage than that specified on the fixture's serial number label.

Power cables and power plug

Power input and throughput cables must be rated 20 A minimum, have three conductors 1.5 mm² (16 AWG) minimum conductor size and an outer cable diameter of 5 - 15 mm (0.2 - 0.6 in). Cables must be hard usage type (SJT or equivalent) and heat-resistant to 90° C (194° F) minimum. In the EU the cable must be HAR approved or equivalent.

If you install a power plug on the power cable, install a grounding-type (earthed) plug that is rated 20 A minimum. Follow the plug manufacturer's instructions. Table 1 shows standard wire color coding schemes and some possible pin identification schemes; if pins are not clearly identified, or if you have any doubts about proper installation, consult a qualified electrician.

Wire color (EU models)	Wire color (US models)	Conductor	Symbol	Screw (US)
Brown	Black	Live	L	Yellow or brass
Blue	White	Neutral	N	Silver
Yellow / green	Green	Ground (Earth)	 ou 	Green

Installing a power input connector on a power cable.

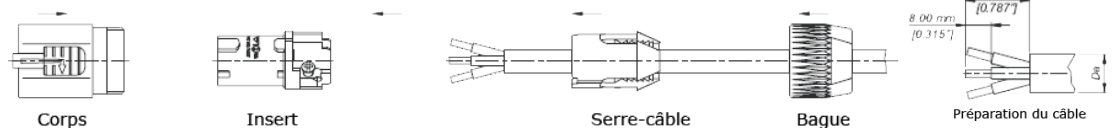

To install a neutrik powercon NAC3FCA input connector on a power cable :

1. Slide the bushing over the cable.
2. Slide the white chuck over cables with a diameter (Da) of 5 - 10 mm (0.2 - 0.4 in.) or the black chuck over cables with a diameter of 10 - 15 mm (0.4 - 0.6 in)
3. Prepare the end of the cable by stripping 20 mm (0.8 in) of the cable's outer jacket.
4. Strip 8 mm (1/3 in) from the end of each of the wires.
5. Insert each of the wire ends into the appropriate terminal (see instructions and table 1 above) and fasten the clamping device using a small fathead screw driver.
6. Push and insert the chuck into the housing (note that there is a raised key on the chuck to ensure that it is oriented correctly)
7. Fasten the bushing using a wrench to a torque of 2.5 Nm (1.8 lb.-ft)

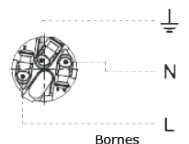

Relaying power to other devices

Warning! Do not connect more than ten LYA200 fixtures in total to AC mains power in an interconnected chain.

Power can be relayed to another device via the light-grey powercon throughput socket that accepts a light-grey powercon NAC3FCB cable connector. Note that blue input and light-grey throughput connectors have different designs : One type cannot be connected to the other.

If you link fixtures in a chain so that they all draw AC mains power via the first fixture, certain points must be respected :



- A hard usage, three-conductor, 16 AWG or 1.5 mm cable with SJT or equivalent cable jacket must be used to connect the first fixture to AC mains power and to interconnect all the fixtures in the chain up to a maximum of seven fixtures in total.
- Light-grey neutrik powercon NAC3FCB connectors must be used to draw AC mains power from the fixtures' power throughput sockets and blue neutrik powercon NAC3FCA connectors must be used to supply power at the fixture's power input sockets.
- No matter what the AC mains power voltage is, do not connect more than ten LYA200 fixtures in total (i.e. including the first fixture) to AC mains power in one interconnected daisy chain using power input and throughput connectors.

6. DATA LINK

A DMX 512 data link is required in order to control a LYA200 via DMX.

The LYA200 has 3-pin XLR connectors for DMX data input and output. The pin-out on all connectors is pin 1 = shield, pin 2 = cold (-), and pin 3 = hot (+).

To add more fixtures or groups of fixtures when the above limit is reached, add a DMX universe and another daisy-chained link.

Tips for reliable data transmission

Use shielded twisted-pair cable designed for RS-485 devices : Standard microphone cable cannot transmit control data reliably over long runs. 24 AWG cable is suitable for runs up to 300 meters (1000 ft) Heavier gauge cable and/or an amplifier is recommended for longer runs.

Connecting the data link

To connect the A200 to data :

1. Connect the DMX data output from the controller to the closest LYA200's male 3-pin XLR DMX input connector.
2. Connect the DMX output of the fixture closest to the controller to the DMX input of the next fixture and continue connecting fixtures output to input.

7. PHYSICAL INSTALLATION

Warning ! The LYA200 must be either fastened to a flat surface such as a stage or wall, or clamped to a truss or similar structure in any orientation using a rigging clamp. Do not apply power to the fixture if it is standing freely or the fixture can be moved.



Warning ! If the fixture can cause injury or damage if it falls, attach an approved safety cable to one of the safety cable attachment points on the base (see "Fixture overview")

Check that all surfaces to be illuminated are minimum 200 mm (7.9 ins) from the fixture, that combustible materials (wood, fabric, paper, etc) are minimum 100 mm (3.9 in) from the head, that there is free airflow around the fixture and that there are no flammable materials nearby.

Make sure that it is impossible for the moving head to collide with another fixture or other object ...

Fastening the fixture to a flat surface

The LYA200 can be fastened to a fixed flat surface that is oriented at any angle. Check that the surface can support at least 10 times the weight of all fixtures and equipment to be installed on it.



Warning ! The supporting surface must be hard and flat or air vents in the base may be blocked, which will cause overheating. Fasten the fixture securely. Do not stand it on a surface or leave it where it can be moved or can fall over. Attach a securely anchored safety cable to the safety cable attachment point (see "Fixture overview") if the fixture is to be installed in any location where it may fall and cause injury or damage if the primary attachment fails.

Mounting the fixture on a truss

The LYA200 can be clamped to a truss or similar rigging structure in any orientation.



Warning ! Use a rigging clamp with an M12 bolt if suspending the fixture from its base. The clamp must be screwed into the central threaded hole in the fixture base. The M12 bolt must protrude 20 - 30 mm (0.8 - 1.2 ins) into the fixture base.

An M12 bolt that is suitable for many types of rigging clamp is supplied with the fixture but you must pass the bolt through the clamp and check that the distance the bolt will protrude into the fixture base is within the 20 - 30 mm limits before using it. If the bolt is not within these limits, you must find an alternative bolt that is.

To clamp a LYA200 to a truss :

1. Check that the rigging structure can support at least 10 times the weight of all fixtures and equipment to be installed on it.

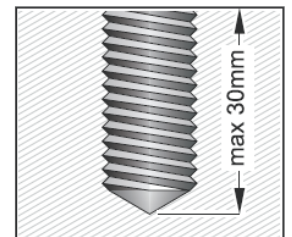
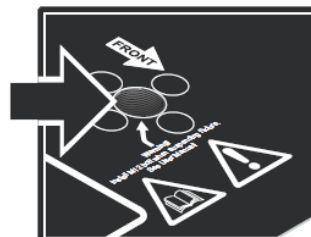

2. Check that the rigging clamp is undamaged and can bear at least 10 times the weight of the fixture. Fasten the clamp to the fixture with a minimum grade 8.8 steel M12 bolt in the threaded hole in the center of the base of the fixture. The bolt must protrude 20 - 30 mm (0.8 - 1.2 ins) into the base of the fixture.
3. Block access under the work area. Working from a stable platform, hang the fixture on the truss with the arrow on the base towards the area to be illuminated. Tighten the rigging clamp.
4. Secure the fixture against clamp failure with a secondary attachment such as an approved safety cable that is rated for the weight of the fixture using one of the attachment points at the edges of the base (see “Fixture overview”) Do not use any other part of the fixture as a safety cable attachment point.
5. Check that the head will not collide with other fixtures or objects.

Hanging the fixture

In some regions, it may be legal to use two safety cables, one looped through one cable attachment point (see “Fixture overview”) and the other looped through the other cable attachment point, to suspend the fixture. If one cable fails, the other will provide secondary attachment.



However, this suspension method is not recommended as it will not hold the base firmly, and moving pan and tilt will cause the fixture and light beam to swing uncontrollably. Instead, we strongly recommend installation using a rigging clamp as described above.

Warning! If you choose to suspend using two cables anyway, you must install a minimum 8.8 grade steel M12 bolt in the rigging clamp hole in the center of the fixture’s base. See figure 2. The bolt must protrude 20 - 30 mm (0.8 - 1.2 ins) into the base. If you do not secure the base in this way, there is a risk that the fixture may separate from the base and fall.

Quick-mount surface mounting bracket

The bracket can be screwed to a surface and the LYA200 mounted on and removed from the bracket in seconds. A securely anchored safety cable or other secondary attachment must be provided if the bracket is used.

8. SETUP



Warning! Read “Safety information” before installing, powering, operating or servicing the fixture.

Control panel and menu navigation

The on board control panel and backlit graphic display are used to set the 200’s DMX address, configure individual fixture settings (personality), read out data and execute service utilities. See “On board control menus” for a complete list of menus and commands.

Using the control buttons

To enter a menu, select a function or apply a selection, press ► (Enter)

Press ▲ (Up) and ▼ (Down) to scroll within a menu or adjust values.

To escape a function or move back one level in the menu structure, press ◀ (Menu / Escape)

Control button reset short cut.

Holding ◀ (Menu/Escape) pressed in and pressing ▲ (Up) forces the fixture to reset.

DMX address setting

The DMX address, also known as the start channel, is the first channel used to receive instructions from the controller. For independent control, each fixture must be assigned its own control channels. Two LYA200 fixtures of the same type may share the same address, however, if identical behaviour is desired. Address sharing can be useful for diagnostic purposes and symmetric control, particularly when combined with the inverse pan and tilt options.

The DMX address is configured using the DMX ADDRESS menu in the control panel.

Beam, aura and FX control

Normal and advanced modes

DMX control mode is selected in the CONTROL MODE menu. The LYA200 has two DMX control modes :

- NORMAL (normal mode – uses 14 DMX channels)
- ADVANCED (advanced mode – uses 25 DMX channels)

NORMAL mode

When the LYA200 is set to NORMAL standard mode, the Beam DMX channels 1 - 14 control the output of both the beam and the LYA200. The behaviour of the beam and aura are identical.

Extended mode

When the LYA200 is set to ADVANCED extended mode :

- Independent control of the beam is available on channels 1 - 14
- A range of FX (pre-programmed effects with combined beam and aura output) is available on channels 15 - 19.
- Independent control of the aura is available on channels 20 - 25.

See “DMX protocol” for details of the DMX commands available in the different modes.

Tailoring performance

Pan and tilt movement

The P/T SPEED settings set the maximum speed of pan and tilt movement. FAST optimizes for speed and SLOW optimizes for smoothness of movement. NORMAL is the default setting and gives a good compromise between these two.

The PAN INVERT and TILT INVERT commands reverse the direction of pan and tilt and the SWAP command sends pan commands to tilt and vice versa. These settings are useful for symmetrical effects with multiple fixtures.

Cooling

FANS gives you a choice of two settings :

- The default setting REGULATED should suit use in all normal situations and ensure excellent service lifetimes for all components.
- FULL maximizes cooling and reduces the operating temperature of the components in the head. It is recommended when the LYA200 is used intensively in a warm environment or in fixed installations. Note that it will give increased fan noise compared to the other cooling modes.

Whatever cooling mode is selected, a thermal cut out shuts down power to the LED if the fixture temperature exceeds safe limits. If this occurs, you must reset the fixture via the control menus or via DMX, or cycle power to the fixture off and on again.

If a thermal shut down occurs, you are pushing the fixture to its limits. Clean the fixture, particularly the air vents, and check that there is sufficient airflow around the fixture. Consider increasing ventilation, reducing the ambient temperature, or switching to FULL mode.

Dimming

DIMMER CURVE provides four dimming options :

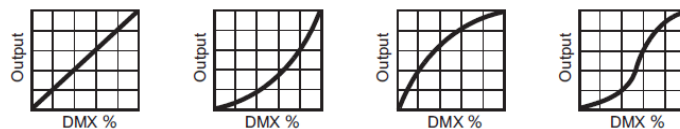

- LINEAR – the increase in light intensity appears to be linear as DMX value is increased.
- SQUARE LAW – light intensity control is finer at low levels and coarser at high levels.
- INVERSE SQUARE LAW – light intensity control is coarser at low levels and finer at high levels.
- S-CURVE – light intensity control is finer at low levels and high levels and coarser at medium levels. Whichever DIMMER CURVE option you select, you can choose between FAST or SMOOTH dimming settings :
- FAST is the default setting. It gives a virtually instantaneous reaction when you dim from one intensity to another but dimming slowly from one intensity to another may appear slightly uneven.
- The SMOOTH setting gives smoother dimming during slow changes in intensity, but it limits the speed of dimming changes slightly. This makes it ideal for slow, smooth dimming, but a short time-lag may be noticeable if you try to dim quickly from one intensity to another.

Restoring factory default settings

The LYA200 factory default settings can be restored by applying a FACTORY SETTING → LOAD command.

9. OPERATION AND EFFECTS



Warning! Read “Safety information” before installing, powering, operating or servicing the LYA200.

This section describes only DMX control features that require particular explanation. See “DMX protocols” for a full list of the DMX channels and values required to control the different effects.

Effects

Beam and aura

The LYA200 has two LED arrays :

- The Beam : The LEDs that provide the main output.
- The Aura: The secondary LED that illuminate the front of the head, provide local diffuse light output and can be set to contrast with the beam output.

See “Beam, aura and FX control” for full details of these modes and how to set them up.

Shutter effect

The electronic ‘shutter’ effect available for the beam and the aura provides instant open and blackout, variable speed regular and random strobe and opening/closing pulse effects as well as burst and sine wave effects.

Dimming

Beam and aura intensity can be adjusted 0 - 100% using electronic dimming. See the available dimming curve options in “Dimming”.

Zoom

The beam can be zoomed from 58° to maximum (narrow) 11° one-tenth peak angles. Aura output is automatically dimmed as the zoom approaches maximum. There is a linear dimming curve from normal aura output when the beam is at 90% zoom, to zero aura output when the beam is at maximum (narrow) zoom.

Pan and tilt

The LYA200 is moving head can be panned through 540 and tilted through 232 . The speed of pan/tilt movement can be adjusted on the DMX fixture control channel 8 and in the fixture’ s on board control panel.

Both NORMAL and ADVANCED control modes offer fine control of pan and tilt. In each case, the main control channel sets the first 8 bits (the most significant byte or MSB) and the fine channel sets the second 8 bits (the least significant byte or LSB) of the 16-bit control byte. In other words, the fine channel works within the position set by the main channel.

Controlling color

Color wheel effects

The electronic ‘color wheel’ effects available for the beam and the aura give the convenience and feel of a mechanical color wheel and let you snap between 33 different full LEE-referenced colors. You can also scroll continuously forwards or backwards through the colors or display random colors at variable speed.

The approximate RGB equivalents of the 'color wheel' colors are given in "LEE colors and RGB equivalents".

Color wheel priority

The color wheel effect channels for the beam and aura have priority and override any color set on the beam RGBW channels or on the aura RGB channels. To use the RGBW and RGB channels, you must set the color wheel effect channel for beam or aura respectively to a DMX value from 000 - 009. If you set either color wheel channel to a DMX value above 009, the color wheel effect overrides RGBW or RGB control.

RGBW and RGB control

RGBW (in raw mode) or RGB (in calibrated mode) color control is available for the beam and RGB control is available for the aura.

CTC (Color Temperature Control)

CTC is available for the beam on the CTC channel 14. Setting this channel to DMX value 20 or above allows you to adjust the beam's overall color temperature, i.e. the color that has been set using the color wheel channel or the RGBW channels. Note that the more saturated the color, the less it will be affected by adjustments in color temperature. The biggest CTC variation is available when displaying white.

Overall color temperature can be varied from 10 000-2500K. The default color temperature is 5600K.

FX : Pre-programmed beam and aura effects

A library of pre-programmed effects in which beam and aura output can be independent or synchronized is available via DMX. These effects are simply called FX in this manual and in the fixture menus. The library is available twice in the DMX channel layout with identical functions and effects, and two different FX can be combined and run simultaneously with one 'superimposed' over the other.

See "FX : pre-programmed effects" for an overview of the FX available.

Effects are selected using the FX select DMX channels 15 and 17. Where modification is possible, the selected FX can be modified using its FX adjust channel. Modifications can include speed, amount, offset, smoothness, etc, depending on the FX selected.

FX sync and random operation

The FX system uses a dedicated internal synchronization clock. If two different FX that repeat in cycles are activated, the FX Sync DMX channel 19 can be used to synchronize them. When two FX are synchronized, the repeat cycle of FX2 is adjusted to ensure that FX2 arrives at the end of a cycle and starts to repeat the cycle at the same time as FX1.

If one FX with a short repeat cycle is combined with another FX with a long repeat cycle, the short FX can repeat twice or more in the time it takes the long FX to repeat once. But if two FX with different repeat cycles are synchronized, the short cycle is adjusted so that it arrives at the end of a cycle at the same time as the long cycle.

Sync shift

The sync shift option modifies FX synchronization so that FX2 runs with a time offset. This means that the FX2 cycle start point is delayed relative to FX1 but the amount of the delay remains constant.

Random operation

Selecting random operation makes random changes in the duration of those FX effects that have repeat cycles. This means that some cycles are shorter and some cycles are longer in a random pattern.

The random sync option changes the duration of FX repeat cycles in a random pattern. Cycle duration is random, but it is always changed by the same amount for FX1 and FX2 so that FX remain synchronized. The overall speed of this synchronized effect is controlled on channel 16.

The random no sync option changes the duration of FX effect cycles in a random pattern, and FX1 and FX2 are not synchronized. The speed of FX1 and FX2 effects are controlled independently on channels 16 and 18 respectively.

FX priority and overriding

If an FX is activated, it overrides any other settings for the parameters that the FX modifies. For example, an FX that modifies the zoom will override any zoom angle set on the zoom channel (DMX channel 3). If the same FX is selected on both the FX1 select and FX2 select channels, only the FX1 adjust channel is active. The FX2 adjust channel is ignored.

If different FX are selected on the FX1 select and FX2 select channels, FX2 is superimposed onto FX1 and FX2 overrides FX1 whenever both FX modify the same parameter.

10. SERVICE AND MAINTENANCE

Warning! Read “Safety information” before servicing the LYA200.

Warning! Disconnect the fixture from AC mains power and allow to cool for at least 10 minutes before handling. Do not view the light output from less than 8.3 meters (27 ft. 3 inches) without shade 4-5 welding goggles. Be prepared for the fixture to light suddenly if connected to power.

Warning! Refer any service operation not described in this user manual to a qualified service technician.



Important! Excessive dust, smoke fluid, and particle build up degrades performance, causes overheating and will damage the fixture. Damage caused by inadequate cleaning or maintenance is not covered by the product warranty.



It is policy to apply the strictest possible calibration procedures and use the best quality materials available to ensure optimum performance and the longest possible component lifetimes. However, LED are subject to wear and tear over the life of the product, resulting in gradual changes in color and overall brightness over many thousands of hours of use. The extent of wear and tear depends heavily on operating conditions and environment, so it is impossible to specify precisely whether and to what extent LED performance will be affected. However, you may eventually need to ask Professional to replace LED if their characteristics are affected by wear and tear after an extended period of use and if you require fixtures to perform within very precise optical and color parameters.



The manufacturer’s LED lifetime data is based on performance under the manufacturer’s test conditions. As with all LED, the gradual reduction in luminous output will be accelerated when LED are used in a fixture, where conditions are much tougher than in manufacturer’s testing. To maximize LED lifetimes, keep the ambient temperature as low as possible and drive the LED no harder and for no longer than necessary.

Cleaning

Cleaning schedules for lighting fixtures vary greatly depending on the operating environment. It is therefore impossible to specify precise cleaning intervals for the LYA200. Environmental factors that may result in a need for frequent cleaning include :

- Use of smoke or fog machines.
- High airflow rates (near air conditioning vents, for example)
- Presence of cigarette smoke.
- Airborne dust (from stage effects, building structures and fittings or the natural environment at outdoor events, for example)

If one or more of these factors is present, inspect fixtures within their first 100 hours of operation to see whether cleaning is necessary. Check again at frequent intervals. This procedure will allow you to assess cleaning requirements in your particular situation.

Use gentle pressure only when cleaning, and work in a clean, well-lit area. Do not use any product that contains solvents or abrasives, as these can cause surface damage.

Warning ! Disconnect from power and allow to cool before cleaning.

To clean the fixture :

1. Disconnect the fixture from power and allow it to cool for at least 10 minutes.
2. Vacuum or gently blow away dust and loose particles from the outside of the fixture and the air vents at the back and sides of the head and in the base with low-pressure compressed air.
3. Remove the central screw from the grill on the front of the head, remove the grill and clean the LED lenses by wiping gently with a soft, clean lint-free cloth moistened with a weak detergent solution. Do not rub the surface hard : lift particles off with a soft repeated press. Dry with a soft, clean, lint-free cloth or low-pressure compressed air. Remove stuck particles with an unscented tissue or cotton swab moistened with glass cleaner or distilled water.



Control menu service utilities

Functions test

The TEST feature provides four test routines, allowing testing of pan/tilt, LEDs and display separately or together without a controller.

11. DMX PROTOCOLS

Normal	Advanced	DMX value	Percent	Function
				Electronic shutter effect
1		0 - 19	0 - 7	Shutter closed
		20 - 49	8 - 19	Shutter open
		50 - 64	20 - 25	Strobe 1 (fast → slow)
		65 - 69	26 - 27	Shutter open
		70 - 84	28 - 33	Strobe 2: opening pulse fast → slow
		85 - 89	34 - 35	Shutter open
		90 - 104	36 - 41	Strobe 3: closing pulse (fast → slow)
		105 - 109	42 - 43	Shutter open
		110 - 124	44 - 49	Strobe 4: random strobe (fast → slow)
		125 - 129	50 - 51	Shutter open
		130 - 144	52 - 57	Strobe 5: random opening pulse (fast → slow)
		145 - 149	58 - 59	Shutter open
		150 - 164	60 - 65	Strobe 6: random closing pulse (fast → slow)
		165 - 169	66 - 67	Shutter open
		170 - 184	68 - 73	Strobe 7: burst pulse (fast → slow)
		185 - 189	74 - 75	Shutter open
		190 - 204	76 - 81	Strobe 8: random burst pulse (fast → slow)
	205 - 209	82 - 83	Shutter open	
	210 - 224	84 - 89	Strobe 9: sine wave (fast → slow)	
	225 - 229	90 - 91	Shutter open	
	230 - 244	92 - 97	Strobe 10: burst (fast → slow)	
	245 - 255	98 - 100	Shutter open	
2		0 - 255	0 - 100	Beam Dimmer 0 → 100% intensity
3		0 - 255	0 - 100	Zoom Wide→narrow
4		0 - 255	0 - 100	Pan Left→right
5		0 - 255	0 - 100	Pan fine Pan fine (Least Significant Byte)
6		0 - 255	0 - 100	Tilt Tilt 0 - 232°
7		0 - 255	0 - 100	Tilt fine Tilt fine (Least Significant Byte)

Normal	Advanced	DMX value	Percent	Function
				Fixture control settings
8		0 - 9	0 - 3	No function
		10 - 14	4 - 5	Reset entire fixture ¹
		15 - 39	6 - 13	No function
		40 - 44	14 - 15	2 PTSP = NORM ²
		45 - 49	16 - 17	PTSP = FAST
		50 - 54	18 - 19	PTSP = SLOW ²
		55 - 59	20 - 21	No function
		60 - 64	22 - 23	Fan mode FULL ²
		65 - 69	24 - 25	No function
		70 - 74	26 - 27	Fan mode REGULATED ²
		75 - 89	28 - 33	No function
		90 - 94	34 - 35	Calibrated color output mode Color Calib = ON ³
		95 - 99	36 - 37	No function
		100 - 104	38 - 40	Raw color output mode COLOR CALIB = OFF ³
		105 - 109	41 - 42	No function
		110 - 114	43 - 44	Fast dimming, speed of changes unrestricted ²
		115 - 119	45 - 46	No function
		120 - 124	47 - 48	Smooth dimming, speed of changes restricted slightly ²
		125 - 249	49 - 97	No function
		250 - 255	98 - 100	Illuminate display
				<p>1. If DMX Reset is disabled in the menu, a reset command can only be executed if channel 2 is set to 232 and channel 1 is set to zero. These values need to be held for 5 seconds before feature is activated. Values must be «snapped to» to function.</p> <p>2. Menu override: setting unaffected by power off/on.</p> <p>3. Value must be held for 3 seconds to activate. Setting unaffected by power off/on.</p>
				Beam Color wheel effect
9		0 - 9	0 - 1	No function.
		10 - 14	2 - 3	LEE 790 - Moroccan pink
		15 - 19	4 - 5	LEE 157 - Pink
		20 - 24	6 - 7	LEE 332 - Special rose pink
		25 - 29	8 - 9	LEE 328 - Follies pink
		30 - 34	10 - 11	LEE 345 - Fuchsia pink
		35 - 39	12 - 13	LEE 194 - Surprise pink
		40 - 44	14 - 15	LEE 181 - Congo Blue
		45 - 49	16 - 17	LEE 071 - Tokyo Blue
		50 - 54	18 - 19	LEE 120 - Deep Blue
		55 - 59	20 - 21	LEE 079 - Just Blue

Normal	Advanced	DMX value	Percent	Function
				Beam Color wheel effect
9		60 - 64	22 - 23	LEE 132 - Medium Blue
		65 - 69	24 - 25	LEE 200 - Double CT Blue
		70 - 74	26 - 27	LEE 161 - Slate Blue
		75 - 79	28 - 29	LEE 201 - Full CT Blue
		80 - 84	30 - 31	LEE 202 - Half CT Blue
		85 - 89	32 - 33	LEE 117 - Steel Blue
		90 - 94	34 - 35	LEE 353 - Lighter Blue
		95 - 99	36 - 37	LEE 118 - Light Blue
		100 - 104	38 - 39	LEE 116 - Medium Blue Green
		105 - 109	40 - 41	LEE 124 - Dark Green
		110 - 114	42 - 43	LEE 139 - Primary Green
		115 - 119	44 - 45	LEE 089 - Moss Green
		120 - 124	46 - 47	LEE 122 - Fern Green
		125 - 129	48 - 49	LEE 738 - JAS Green
		130 - 134	50 - 51	LEE 088 - Lime Green
		135 - 139	52 - 53	LEE 100 - Spring Yellow
		140 - 144	54 - 55	LEE 104 - Deep Amber
		145 - 149	56 - 57	LEE 179 - Chrome Orange
		150 - 154	58 - 59	LEE 105 - Orange
		155 - 159	60 - 61	LEE 021 - Gold Amber
		160 - 164	62 - 63	LEE 778 - Millennium Gold
		165 - 169	64 - 65	LEE 135 - Deep Golden Amber
		170 - 174	66 - 67	LEE 164 - Flame Red
		175 - 179	68 - 69	Open
		180 - 201	70 - 78	Clockwise, fast → slow
		202 - 207	79 - 80	Stop (this will stop wherever the color is at the time)
		208 - 229	81 - 89	Counter -clockwise, slow → fast
		230 - 234	90 - 91	Open
				Random color
		235 - 239	92 - 93	Fast
		240 - 244	94 - 95	Medium
		245 - 249	96 - 97	Slow
		250 - 255	98 - 100	Open
10		0-255	0-100	Beam Red Red 0 → 100%
11		0-255	0-100	Beam Green Green 0 → 100%
12		0-255	0-100	Beam Blue Blue 0 → 100%

Normal	Advanced	DMX value	Percent	Function
13		0-100	0-100	Beam white White 0 → 100% Note: if channel 8 is set to 90-94, this channel has no effect –white LEDs are activated by RGB mixing Color
14		0-19 20-255	0-07 8-100	Beam CCT No Function CTC 10 000K → 2 500K
	15	0-255	0-100	FX1 select Pre-programmed effect 1 selection (see “FX: pre-programmed effects”)
	16	0-255	0-100	FX1 adjust, sync speed adjust Zero → maximum <ul style="list-style-type: none"> If no sync set on channel 19, adjusts FX1 If sync set on channel 19, adjusts synchronized FX1+FX2 speed
	17	0-255	0-100	FX2 select Pre-programmed effect 2 selection (see “FX: pre-programmed effects” on page 23)
	18	0-255	0-100	FX2 adjust Zero → maximum <ul style="list-style-type: none"> If no sync set on channel 19, adjusts FX2 If sync set on channel 19, has no effect
	19	0-49	0-19	Sync (FX synchronization) No sync <ul style="list-style-type: none"> FX1 and FX2 run through cycles independently Cycle duration is regular Channel 16 and channel 18 adjust FX1 and FX2 independently
		50-100	20-100	Sync <ul style="list-style-type: none"> FX1 and FX2 run through cycles in sync Cycle duration is regular Channel 16 adjusts overall speed, channel 18 has no effect

Aura control

Normal	Advanced	DMX value	Percent	Function
				Electronic shutter effect
	20	0 - 19	0 - 7	Shutter closed
		20 - 24	8 - 9	Shutter open
		25 - 64	10 - 25	Strobe 1 (fast → slow)
		65 - 69	26 - 27	Shutter open

Normal	Advanced	DMX value	Percent	Function
	20	70 - 84	28 - 33	Strobe 2: opening pulse (fast → slow)
		85 - 89	34 - 35	Shutter open
		90 - 104	36 - 41	Strobe 3: closing pulse (fast → slow)
		105 - 109	42 - 43	Shutter open
		110 - 124	44 - 49	Strobe 4: random strobe (fast → slow)
		125 - 129	50 - 51	Shutter open
		130 - 144	52 - 57	Strobe 5: random opening pulse (fast → slow)
		145 - 149	58 - 59	Shutter open
		150 - 164	60 - 65	Strobe 6: random closing pulse (fast → slow)
		165 - 169	66 - 67	Shutter open
		170 - 184	68 - 73	Strobe 7: burst pulse (fast → slow)
		185 - 189	74 - 75	Shutter open
		190 - 204	76 - 81	Strobe 8: random burst pulse (fast → slow)
		205 - 209	82 - 83	Shutter open
		210 - 224	84 - 89	Strobe 9: sine wave (fast → slow)
		225 - 229	90 - 91	Shutter open
	230 - 244	92 - 97	Strobe 10: burst (fast → slow)	
	245 - 255	98 - 100	Shutter open	
	21	0-255	0-100	Aura dimmer 0 → 100% intensity
				Beam Color wheel effect
	22	0 - 9	0 - 1	Open. RGBW color mixing enabled
		10 - 14	2 - 3	LEE 790 - Moroccan pink
		15 - 19	4 - 5	LEE 157 - Pink
		20 - 24	6 - 7	LEE 332 - Special rose pink
		25 - 29	8 - 9	LEE 328 - Follies pink
		30 - 34	10 - 11	LEE 345 - Fuchsia pink
		35 - 39	12 - 13	LEE 194 - Surprise pink
		40 - 44	14 - 15	LEE 181 - Congo Blue
		45 - 49	16 - 17	LEE 071 - Tokyo Blue
		50 - 54	18 - 19	LEE 120 - Deep Blue
		55 - 59	20 - 21	LEE 079 - Just Blue
		60 - 64	22 - 23	LEE 132 - Medium Blue
		65 - 69	24 - 25	LEE 200 - Double CT Blue
		70 - 74	26 - 27	LEE 161 - Slate Blue
		75 - 79	28 - 29	LEE 201 - Full CT Blue
		80 - 84	30 - 31	LEE 202 - Half CT Blue
		85 - 89	32 - 33	LEE 117 - Steel Blue
		90 - 94	34 - 35	LEE 353 - Lighter Blue
		95 - 99	36 - 37	LEE 118 - Light Blue
		100 - 104	38 - 39	LEE 116 - Medium Blue Green
	105 - 109	40 - 41	LEE 124 - Dark Green	
	110 - 114	42 - 43	LEE 139 - Primary Green	
	115 - 119	44 - 45	LEE 089 - Moss Green	
	120 - 124	46 - 47	LEE 122 - Fern Green	

Normal	Advanced	DMX value	Percent	Function
	22	125 - 129	48 - 49	LEE 738 - JAS Green
		130 - 134	50 - 51	LEE 088 - Lime Green
		135 - 139	52 - 53	LEE 100 - Spring Yellow
		140 - 144	54 - 55	LEE 104 - Deep Amber
		145 - 149	56 - 57	LEE 179 - Chrome Orange
		150 - 154	58 - 59	LEE 105 - Orange
		155 - 159	60 - 61	LEE 021 - Gold Amber
		160 - 164	62 - 63	LEE 778 - Millennium Gold
		165 - 169	64 - 65	LEE 135 - Deep Golden Amber
		170 - 174	66 - 67	LEE 164 - Flame Red
		175 - 179	68 - 69	Open
				Color wheel rotation effect
				Clockwise, fast → slow
		180 - 201	70 - 78	Stop (this will stop wherever the color at the time)
		202 - 207	79 - 80	
		208 - 229	81 - 89	Counter -clockwise, slow → fast
		230 - 234	90 - 91	Open
				Random color
		235 - 239	92 - 93	Fast
		240 - 244	94 - 95	Medium
		245 - 249	96 - 97	Slow
		250 - 255	98 - 100	Open
	23	0-255	0-100	Beam Red Red 0 → 100%
	24	0-255	0-100	Beam Green Green 0 → 100%
	25	0-255	0-100	Beam Blue Blue 0 → 100%

Note : DMX values labelled «No function» will have no effect - the last functional value will be used.

12. FX: PRE-PROGRAMMED EFFECTS

The table below lists the pre-programmed effects that can be selected on DMX channels 15 and 17. Two effects can be superimposed by selecting one effect on channel 15 and a different effect on channel 17.

Type	DMX value	Percent	Function	FX adjust
			Dimmer sync	
Aura Sync	0 - 9	0 - 3	Idle	n/a
	10 - 12	4	Dimmer sync	n/a
	13 - 15	5	Strobe sync	n/a
	16 - 18	6 - 7	Dimmer + strobe sync	n/a
	19 - 21	8	Aura color sync	n/a
	22 - 24	9	Aura all sync	n/a
	25 - 39	10 - 15	Reserved	n/a
Intensity FX	40 - 42	16	Aura strobe delay	Trigger Delay
	43 - 45	17	Strobe alternate single	Speed
	46 - 48	18	Strobe alternate dual	Speed
	49 - 51	19 - 20	Strobe alternate triple	Speed
	52 - 54	21	3- step strobe	Speed
	55 - 60	22 - 23	Reserved	n/a
	61 - 63	24	Intensity random alternate	Speed
	64 - 66	25	Aura ramp, Beam flash	Speed
	67 - 69	26 - 27	Beam ramp, Aura flash	Speed
	70 - 72	28	Intensity Aura, Beam ramp	Speed
	73 - 75	29	Intensity Beam, Aura ramp	Speed
76 - 99	30 - 38	Reserved	n/a	
Color FX	100 - 102	39	Aura color offset	Color offset
	103 - 108	40 - 42	Reserved	n/a
	109 - 111	43	Hue shimmer	Amount
	112 - 114	44	Saturation shimmer	Amount
	115 - 126	45 - 49	Reserved	n/a
	127 - 129	50	Color strobe	n/a
	130 - 132	51	Color offset strobe	Color offset on strobe
	133 - 135	52	Aura color strobe	n/a
	136 - 138	53	Aura color offset strobe	Aura color offset on strobe
	139 - 141	54 - 55	Color spikes	Strength
142 - 159	56 - 62	Reserved	n/a	
			Zoom / color offset	
Zoom FX	160 - 162	63	Color zoom ramp in	Speed
	163 - 165	64	Color zoom ramp out	Speed
	166 - 168	65	Color zoom fade in	Speed
	169 - 171	66	Color zoom fade out	Speed
	172 - 174	67 - 68	Reserved	n/a
	175 - 177	69	Zoom ramp up	Speed
	178 - 180	70	Zoom ramp down	Speed
	181 - 219	71 - 85	Reserved	n/a
Reserved	220 - 255	86 - 100	Reserved	n/a

13. LEE COLORS AND RGB EQUIVALENTS

The table below gives approximate RGB equivalents for the LEE colors available in the standard A200's color wheel effects for the Beam (on DMX channel 9 in normal and advanced modes) and Aura (on DMX channel 22 in advanced mode only)

Lee no.	Name	DMX Integer		
		Red	Green	Blue
790	Moroccan Pink	255	235	052
157	Pink	214	134	048
332	Special rose pink	255	000	044
328	Follies Pink	255	059	113
345	Fuchsia Pink	255	138	219
194	Surprise Pink	226	175	226
181	Congo Blue	040	001	255
071	Tokyo Blue	000	000	255
120	Deep Blue	000	078	255
079	Just Blue	000	199	255
132	Medium Blue	000	255	234
200	Double CT Blue	149	246	255
161	State Blue	137	255	227
201	Full CT Blue	213	220	222
202	Half CT Blue	219	232	175
117	Steel Blue	205	255	199
353	Lighter Blue	115	255	165
118	Light Blue	006	255	143
116	Medium blue green	000	255	94
124	Dark Green	029	255	000
139	Primary Green	032	223	000
089	Moss Green	075	255	000
122	Fern Green	080	232	000
738	JAS Green	108	226	000
088	Lime Green	145	194	000
100	Spring Yellow	210	255	000
104	Deep Amber	225	232	000
179	Chrome Orange	023	215	000
105	Orange	247	214	000
021	Gold Amber	255	163	000
778	Millennium Gold	255	152	000
135	Deep Golden Amber	255	108	000
164	Flame Red	255	080	000

14. ON BOARD CONTROL MENUS

Menu	Item	Options	Notes (Default settings in bold print)
DMX address		1 - XXX	DMX address (default address =1) The DMX address range is limited so that the fixture will always have enough DMX channels in the 512 available.
Cont mode	Advanced		Independent control of Beam and Aura, FX available (fixture uses 25 DMX channels)
	Normal		Linked control of beam and aura using beam channels, aura copies beam (fixture uses 14 DMX channels)
Motor setting	P/T speed	Normal/Fast/Slow	Pan and tilt speed normal / fast / slow
	P/T swap	No/Yes	Swap pan and tilt (pan commands move tilt and vice versa) - off / on
	Pan invert	Normal/Reverse	Pan inversion (reverse direction pan control)
	Tilt invert	Normal/Reverse	Tilt inversion (reverse direction tilt control)
Personality	Fans	Regulated	Cooling fan speed thermostatically regulated
		Full	Max. cooling fan speed
	Dimmer mode	Linear	Linear dimming curve
		Square law	Square law dimming curve
		Inv square law	Inverse square law dimming curve
		S-curve	S-curve dimming curve
	Dimmer speed	Fast	Fast dimming with unrestricted speed
		Smooth	Smooth dimming with restricted speed
	DMX reset	Off	Disable reset via DMX
		On	Enable reset via DMX
	Display	On	Display is always on
		2mn	Display switches off and goes into Sleep mode if the controls have not been pressed for 2 minutes.
	Display intensity	10-100	Display intensity. Default = 100
Error mode	Normal	Display errors at 100% intensity (regardless of display intensity setting) and illuminate the service light	
	Silent	Silent error mode. The error message does not appear in the display, but the service lamp is illuminated	

Menu	Item	Options	Notes (Default settings in bold print)
Test	Test all		Test LEDs and pan/tilt movement
	Test LED		Test LEDs only
	Test pan & tilt		Test pan/tilt movement only
	Test display		Test all segments in on board display panel
Info	Version	V1.0	CPU firmware version
Factory setting	Load		Return all settings (except calibrations) to factory defaults

15. DISPLAY MESSAGES

Message	Appears when...	What to do
RST (Reset)	... the fixture is indexing effects at start up.	Wait for reset to complete.
SRST (Serial reset)	... the fixture has received a reset command.	Wait for reset to complete. Note that you can set PERSONALITY → DMX RESET to OFF to prevent accidental DMX reset commands.
HTSE - HEAD TMP SEN ERR	...there is a malfunction in the head temperature sensor circuit.	Contact service for assistance.
LTSE - LAMP TMP SEN ERROR	...there is a malfunction in the LED temperature sensor circuit.	Contact service for assistance.
FBEP - PAN FBACK ERR FBET - TILT FBACK ERR	...there is a malfunction in the optical pan/tilt monitoring circuit (e.g. sensor defective). After a time-out, the effect in question stops in a random position.	Reset fixture. Contact service if problem continues.
PSER - PAN SENSOR ERR TSER - TILT SENSOR ERR	...there is a malfunction in the electrical indexing circuit for pan, tilt or one of the drivers.	Reset fixture. Contact service if problem continues.
FANS - FAN ERROR	...there is a fan or fan driver error.	Check that fan on rear of head is free to rotate freely. Contact service for assistance.

16. SPECIFICATIONS

Dimensions	305 mm x 305 mm x 358 mm
Weight	5.6 kg (12.3 lbs.) without accessories
Beam color mixing	RGBW
Aura (secondary lens array illumination) color mixing	RGB
Beam color temperature control	CTO, variable 10 000 - 2500 K
Beam and aura electronic 'color wheel' effect	33 LEE-referenced colors plus white, variable-speed color wheel rotation effect and random color
Beam and aura independent shutter effects	Electronic, with regular and random pulse, burst and strobe effects
Pre-programmed effects	Range of independent and synchronized beam and aura FX, two combinable
Electronic dimming	Independent beam and aura, four dimming curve options
Zoom	11° - 58° (one-tenth peak angle)
Pan	540°
Tilt	232°
Pan and tilt speed	Adjustable via on board control panel and DMX
Light source	Osram ostar high-power long-life emitters
Total luminous output	3850 lumens (zoom at maximum)
Control options	Independent or synchronized Beam and Aura control
Control	DMX
Control resolution	8-bit, with 16-bit control of pan & tilt
DMX channels	14/25
Setting and addressing	Control panel with backlit graphic display
Protocol	USITT DMX512-A
Color	Black
Housing	High-impact flame-retardant thermoplastic
Protection rating	IP 20
Mounting points	M12 hole for rigging clamp, attachment points for surface-mounting bracket
Orientation	Any
Minimum distance to combustible materials	100 mm (3.9 in.) from fixture
Minimum distance to illuminated surfaces	200 mm (7.9 ins.) from fixture
Location	Indoor use only, must be fastened to structure or surface
AC power input	Neutrik powercon NAC3MPA input socket (blue)

AC power throughput	Neutrik powercon NAC3MPB output socket (grey)
DMX data in/out	3-pin locking XLR
AC power	100-240 V nominal, 50/60 Hz
Maximum total power consumption	260W
Power supply unit	Auto-ranging electronic switch mode
Power consumption, all effects static, zero light output	<15W
Typical Power and Current	
100 V, 60 Hz	236W, 2.4 A, PF 0.994
120 V, 60 Hz	234W, 2.0 A, PF 0.992
208 V, 60 Hz	229W, 1.2 A, PF 0.970
230 V, 50 Hz	228W, 1.1 A, PF 0.959
240 V, 50 Hz	228W, 1.0 A, PF 0.953
PF = power factor. Measurements made at nominal voltage with all LED at full intensity. Allow for a deviation of +/- 10%.	
Cooling	Forced air (temperature-regulated, low noise, user-definable levels)
Maximum ambient temperature (Ta max.)	40° C (104° F)
Minimum ambient temperature (Ta min.)	5° C (41° F)
Total heat dissipation (calculated, +/- 10%)	820 BTU / hr

LINEARLEDS



Linear Technologie • 11 rue du Puits Rochefort • 42 100 Saint-Etienne
Tél: +33 (0)4 77 81 49 49 • Fax: +33 (0)4 77 81 49 40 • www.lineartech.fr